

CYLINDER HEAD/VALVES

Remove the set pins.

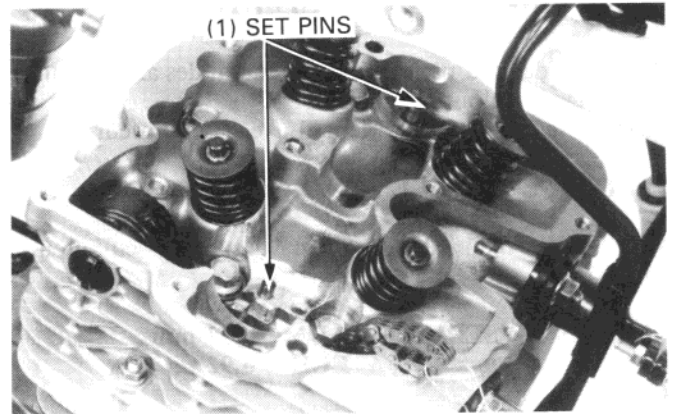

CAMSHAFT BEARING INSPECTION

Turn the outer race of each bearing with your finger. The bearings should turn smoothly and quietly. Also check that the bearing inner race fits tightly on the camshaft.

If the outer races do not turn smoothly and quietly, replace the bearings.

Remove the camshaft ball bearings from the camshaft.

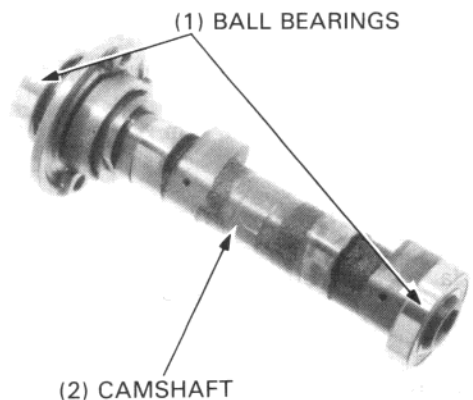

CAMSHAFT INSPECTION

Check each cam lobe for wear or damage. Measure the cam lobe height.

SERVICE LIMITS:

INTAKE: 31.05 mm (1.222 in)

EXHAUST: 31.00 mm (1.220 in)

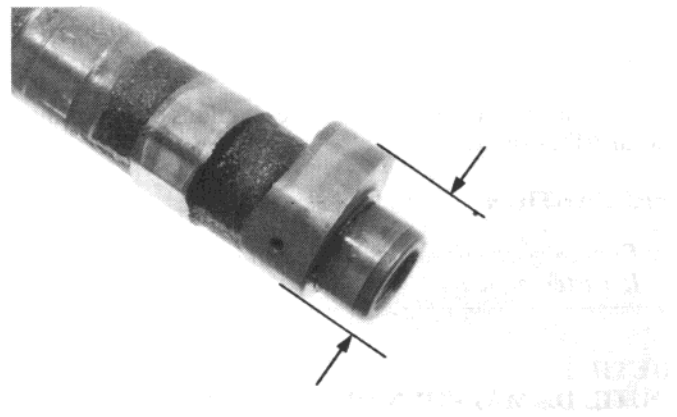

Check camshaft runout with a dial indicator. Support both ends of the camshaft with V-blocks. Actual runout is 1/2 of the total indicator reading.

SERVICE LIMIT: 0.04 mm (0.002 in)

