

## Electrical servicing

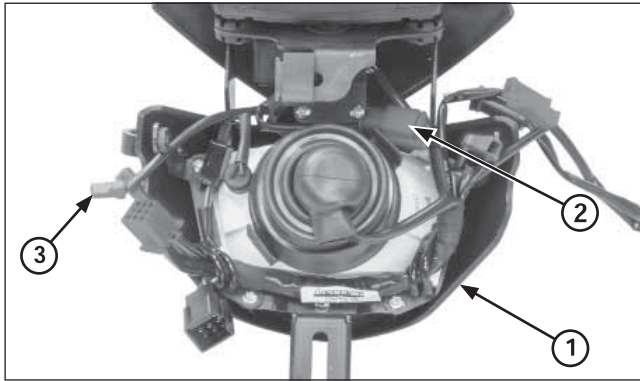

- (1) HOUSING FOR THE UPPER HEADLIGHT  
 (2) CONNECTOR 6P  
 (3) CONNECTOR 3P

### Checking the speed sensor

Remove the housing for the upper headlight.

Check if there are loose or defective contacts in the connector 3P (white) of the speed sensor.

Disconnect the connector 3P (white) of the speed sensor.

Start the engine.

Measure the voltage between the terminals of the connector 3P (white) of the speedometer on the wire side.

**Connection:** Red (+) and Blue (-)

**Standard:** 5V approximately.

If the standard voltage appears, replace the speed sensor.

If there is no standard voltage, check the following:

- The blue wire in case there is an open circuit.
- The red wire in case there is an open circuit.
- Speedometer.

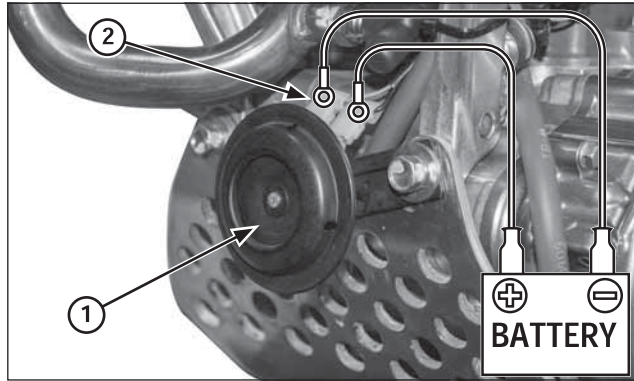

- (1) HORN  
 (2) CONNECTORS

### Horn

#### Checks:

If the engine starts but the horn does not work, check the following:

- Loose connection.

If there is no loose connector, disconnect the connectors from the horn.



Connect the 12 V battery to the horn's terminals. If the horn does not sound, replace it with a new unit and repeat the test.

If the horn sounds, do the following procedure:

Start the engine and check the voltage between the following terminals of the connector 9P (white) on the harness side:

**Connection:** Black (+) and Ground (-)

**Standard:** 12V approximately.

	GND	Ho
FREE		
PUSH		
COLOR	G	LG

HORN SWITCH

If there is no voltage, check the following:

- Open circuit in the Black wire between the ignition relay and the connector 9P (white) on the handlebar.

If there is voltage, check the continuity between the terminals in each switch position, as shown in the table.