

## Frame servicing

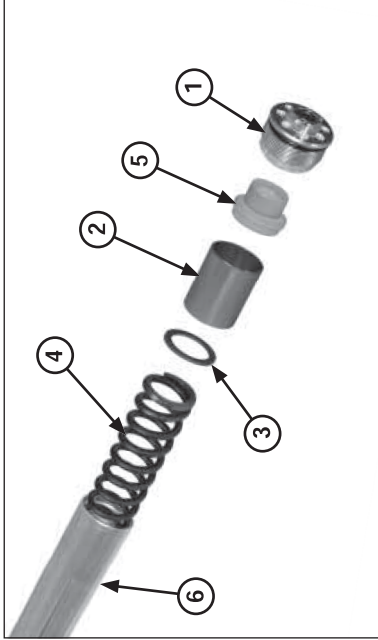

- (1) FORK BOLT
- (2) DISTANCE COLLAR
- (3) SPRING SEAT
- (4) FORK SPRING
- (5) TAPERED BUSHING
- (6) FORK TUBE

### Left Fork Disassembly

Before disassembling the fork, clean the entire sliding surface and the bottom of the fork slider.

Be careful not to scratch the fork tube.

A scratched fork tube will damage the seal, causing an oil leak.

The fork bolt under spring pressure.

Before removing the fork bolt, turn the pre-load adjuster softest position.

Remove the fork bolt from the fork tube.

Remove the tapered bushing, distance collar, spring seat and fork spring.

Pour out the fork fluid.

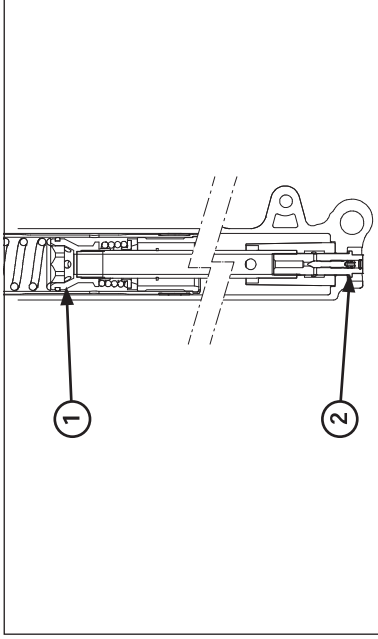

- (1) CILINDER ASSY
- (2) CENTER BOLT

Hold the axle holder in a vise protected with a piece of wood or soft jaws to avoid damage.  
Do not overtighten.

Hold the cylinder assembly using the special tool and tighten the central screw to the specified torque.

### Tool:

**Fork damper holder**

**07930-KA50100**

Remove the center bolt and sealing washer.

Remove the following items using the same procedure as the right fork disassembly (page 4-2):

- Dust seal
- Stop ring
- Fork tube, unlocking guide bushing on the fork leg.

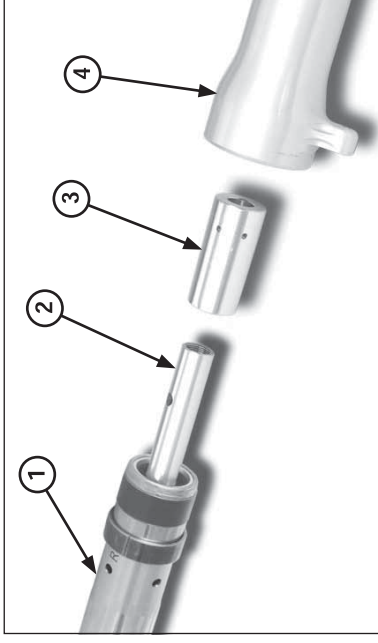

- (1) FORK TUBE
- (2) CILINDER ASSY
- (3) TAPERED BUSHING
- (4) FORK SLIDER

Remove the tapered bushing from the cilinder assy.

## NOTICE

*Be careful not to damage the tapered bushing.*

Remove the cilinder assy from the fork tube.

Remove the following items using the same procedure as the right fork disassembly (page 4-2):

- Oil seal
- Back-up ring
- Guide bushing
- Fork tube bushing