

## REAR WHEEL/SUSPENSION

Press the needle bearing into the swingarm with the marked side facing out.

Pack the new needle bearing with grease (Shell Alvania EP2 or equivalent).

Press the needle bearing into the left swingarm pivot until the depth from the swingarm pivot surface is 7.0 – 8.0 mm (0.28 – 0.31 in), using the special tools and a hydraulic press.

### TOOLS:

Driver

Attachment, 40 x 42 mm

Pilot, 32 mm

07749-0010000

07746-0010900

07MAD-PR90200

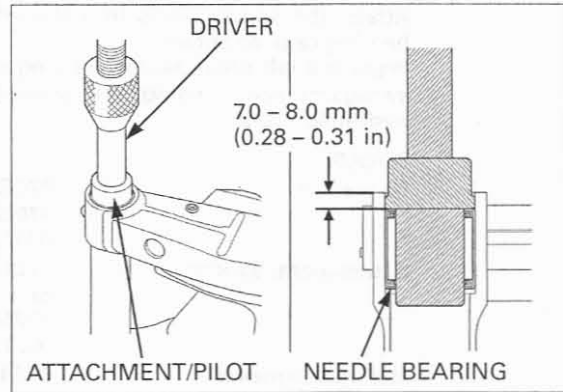

## ASSEMBLY

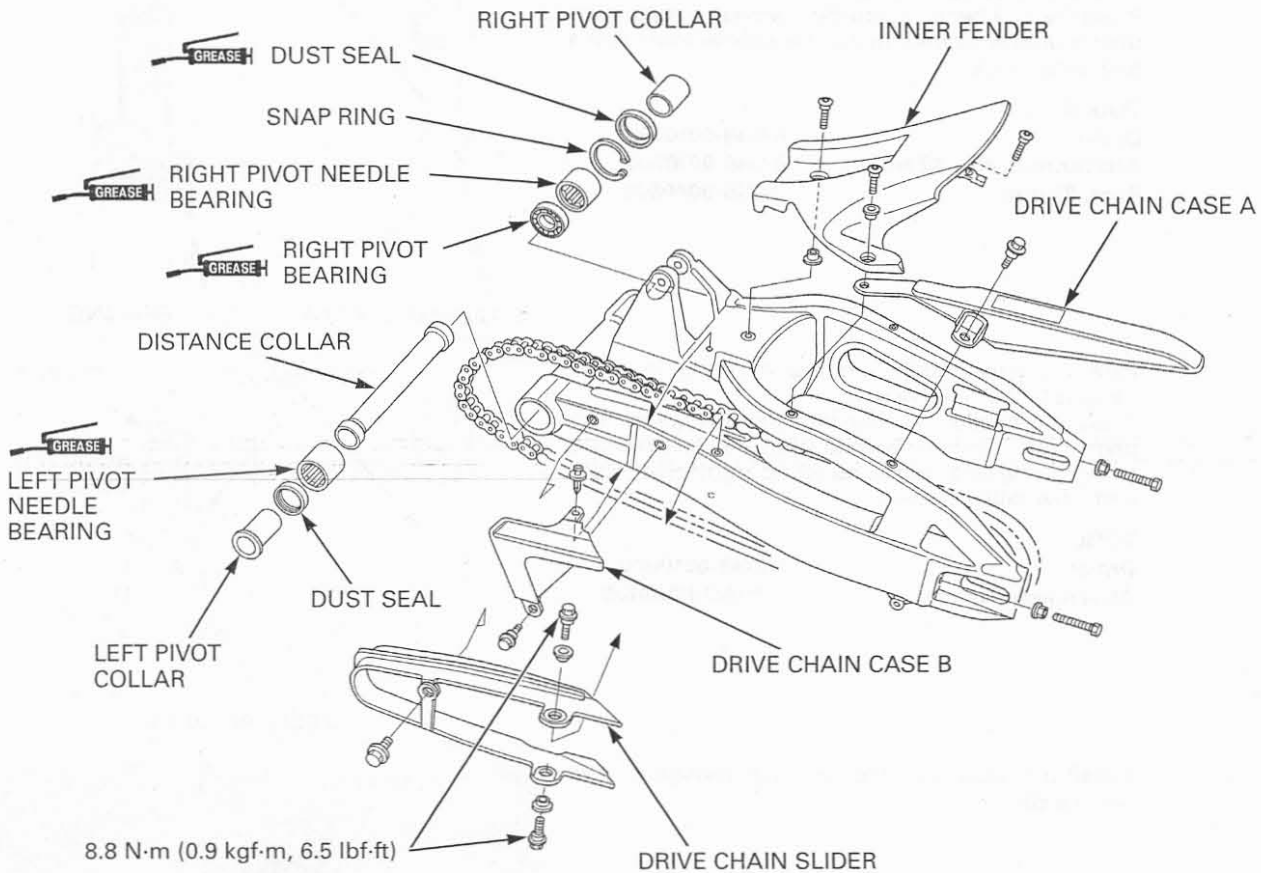

Install the distance collar from the left side pivot. Apply grease (Shell Alvania EP2 or equivalent) to new dust seal lips. Install the dust seals and pivot collars into the swingarm pivot.

