

Fig. 8-9 ① Stator coil
② Tester

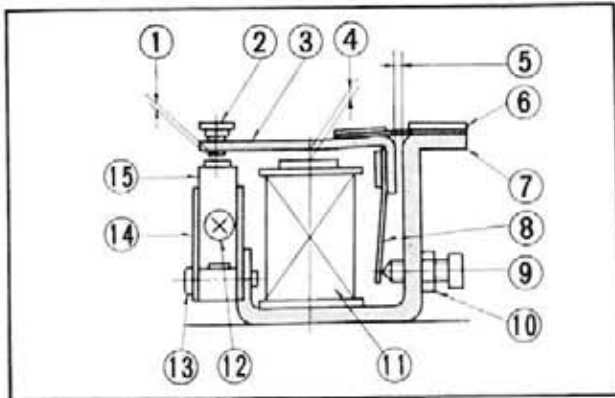

Fig. 8-10 ① Point gap
② Lower contact
③ Armature
④ Core gap
⑤ Yoke gap
⑥ Spring
⑦ Yoke
⑧ Adjusting spring
⑨ Voltage adjusting screw
⑩ Lock nut
⑪ Coil
⑫ Point gap adjusting screw
⑬ Core gap adjusting screw
⑭ Contact set
⑮ Upper contact

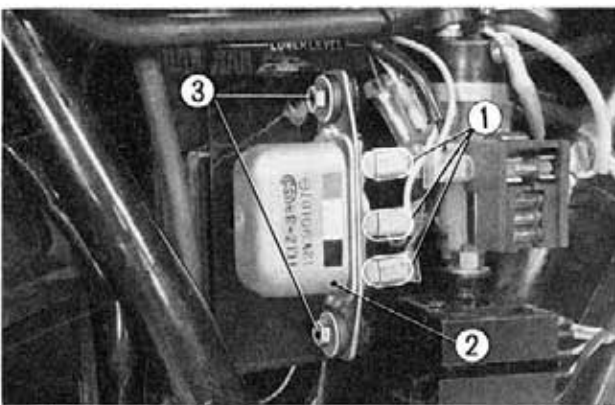

Fig. 8-11 ① Connectors
② Regulator
③ Regulator setting bolts

2. Stator coil continuity test

The insulation and open circuit condition of the stator coil is checked with a tester. If there are no continuity between the three terminals, the coil has an open circuit, in either case, the coil is defective and must be replaced. The rated resistance value is 0.2Ω . (Fig. 8-9)

d. Reassembly

Reassembly is performed in the reverse order of disassembly.

8-3 REGULATOR

a. Description

The regulator is a dual contact type regulator and it functions by opening or closing the resistance circuit to the alternator field coil; in this way, the output voltage is maintained at a constant level.

It is mounted in the center of the frame within the battery cover. (Fig. 8-10)

b. Disassembly

1. Detach the battery cover and remove the regulator by unscrewing the two setting bolts. (Fig. 8-11)
2. Remove the regulator cover by unscrewing the two setting screws.

c. Inspection

1. If an adjustment is necessary to the regulator after checking the voltage or charging current by the procedure outlined in the test section, perform the adjustment by the following manner.

If the charging current or battery voltage is too low, loosen the voltage adjusting screw lock nut and turn the adjusting screw clockwise. If the charging current or battery voltage is excessively high, turn the screw in the opposite direction. (Fig. 8-12)

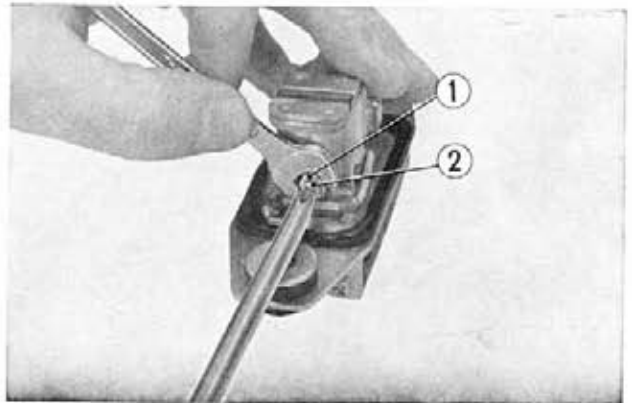

Fig. 8-12 ① Adjusting screw lock nut
② Adjusting screw