

- 5) Separate the bottom case from the front fork pipe by removing the fork bolt cap.
To remove, use tool "Hollow set Wrench 07917-3230000."
- 6) Remove the dust seal. Remove the snap ring by using plier. (Fig. 40)
- 7) Separate the fork pipe from the bottom pipe.
- 8) Separate the underseat from the front fork pipe.
- 9) Remove the oil seal.

B. INSPECTION

- 1) Examine if the front fork piston ring is not worn.
- 2) Check the suspension spring for free length and as-installed tension.
- 3) Inspect the front bottom case for wear.
- 4) Determine if the fork pipe is not cracked or damaged excessively beyond use.

C. ASSEMBLY

- 1) Wash all parts thoroughly in cleaning solvent.
- 2) Slide the under seat into place in the fork pipe; insert the suspensions spring. (Fig. 41)

Note:

Before installation, apply Automobile automatic transmission fluid.

- 3) Assemble the fork pipe with the bottom case.

Note:

Use suitable sealer to the fork bolt cap

- 4) Drive the oil seal into place in the bottom case. Use tool "Oil Seal Installer. 07947-3550000. (Fig. 42)
- 5) Place the snap ring in the groove in the bottom case. Make sure it seats properly.
- 6) Pour the specified amount of HONDA automobile automatic transmission fluid oil in the front fork. (Fig. 43)
Specified quantity..... 4.4~4.70ozs
(130~140cc)

Note:

The fork should be filled with the fluid be-

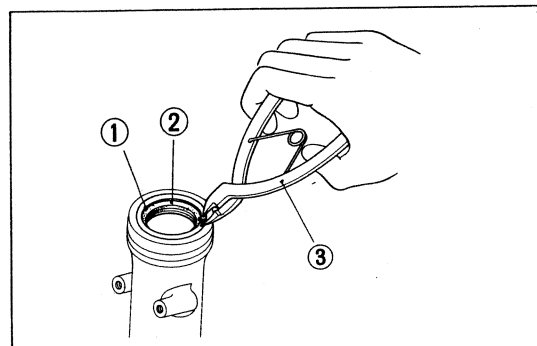

Fig. 40 ① Snap ring ② Oil seal ③ Snap ring plier

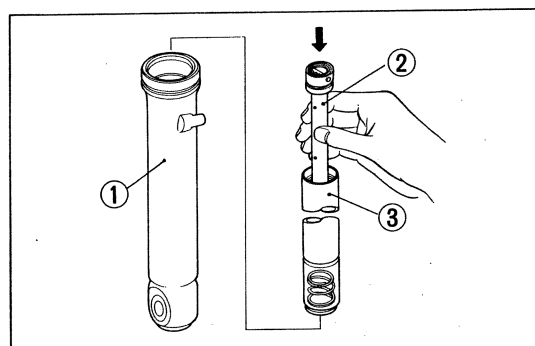

Fig. 41 ① Front fork bottom pipe
② Bottom pipe ③ Fork pipe

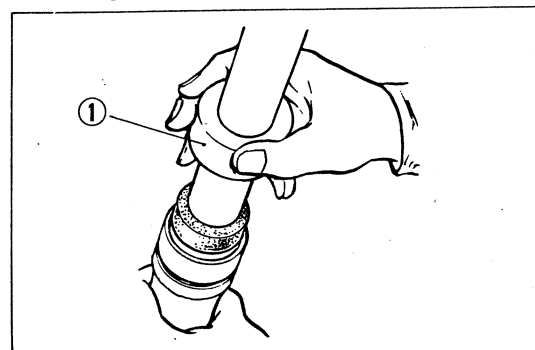

Fig. 42 ① Oil seal installer

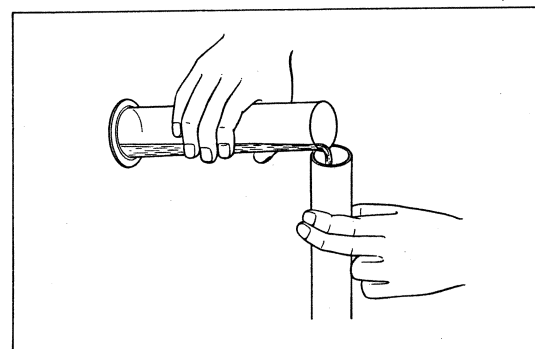

Fig. 43