

2-H15

F-47

Radio
(GL1200De • IE • Ae • Df • If • Af • Lf)

Radio
(GL1200De • IE • Ae • Df • If • Af • Lf)

Radio
(GL1200De • IE • Ae • Df • If • Af • Lf)

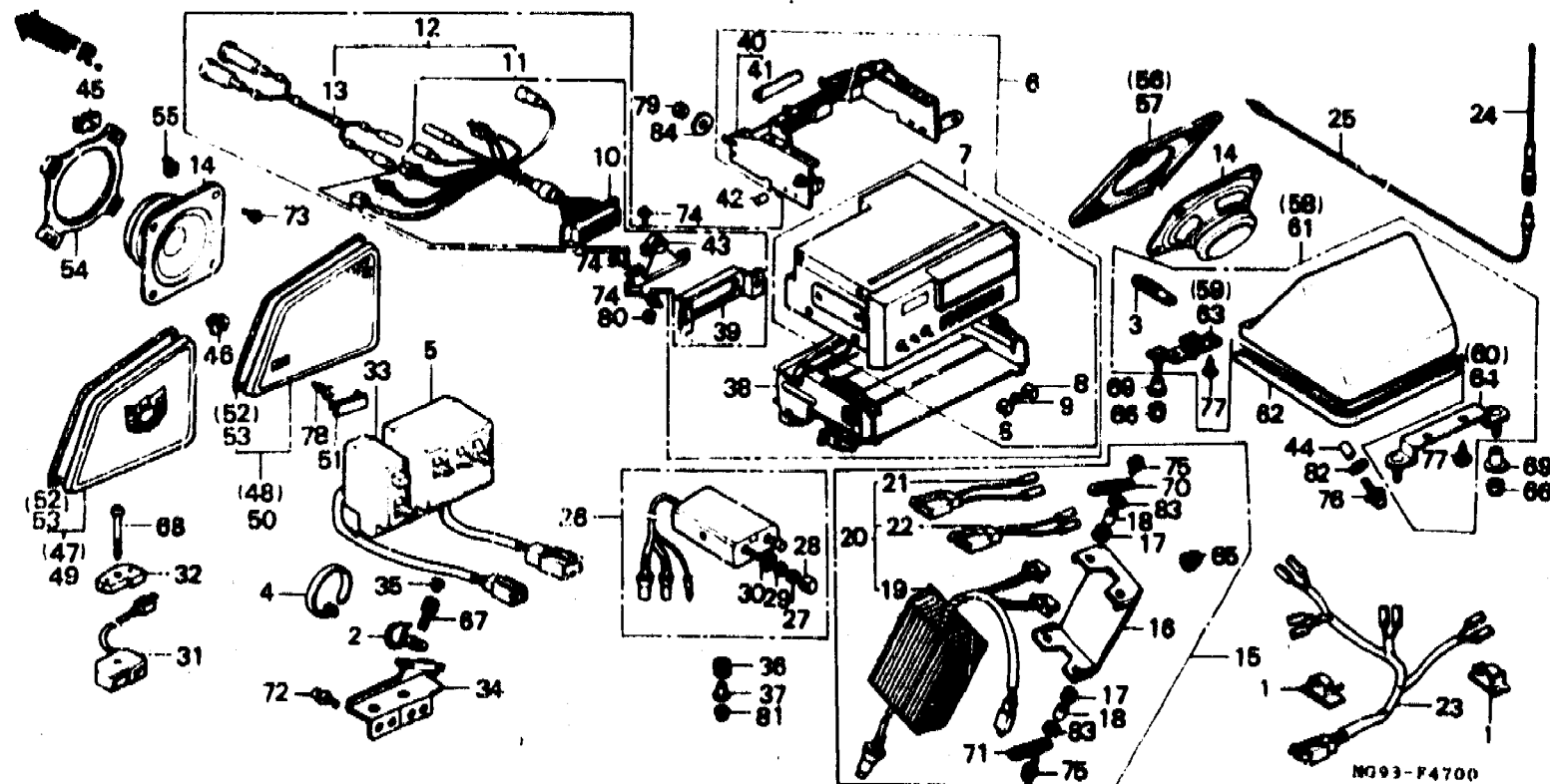

Item d'entretien	T.D.R.	N° de réf.	N° de pièce	Description	N° de reques GL1200						N° de série	Code de zone	
					i	Di	Ir	Ar	Dr	Ir			Ar
		77	93903-25220	VIS AUTO-TARAUDEUSE, 5X12	-	-	-	-	-	-	8		
		78	93903-34480	VIS AUTO-TARAUDEUSE, 4X16	-	(2)	(2)	2	-	(2)	2	2	CM,E,F,U
		79	94001-04080-0S	ECROU HEX., 4MM	-	(2)	-	2	(2)	-	2	-	ED,IT,SD,SW
		79	94001-04080-0S	ECROU HEX., 4MM	-	(1)	(1)	1	(1)	(1)	1	1	CM,E,ED,F,IT
		80	94001-06000-0S	ECROU HEX., 6MM	-	(2)	(2)	2	(2)	(2)	2	2	SD,SW,U
		80	94001-06000-0S	ECROU HEX., 6MM	-	(2)	(2)	2	(2)	(2)	2	2	CM,E,ED,F,IT
		81	94050-05080	ECROU DE BRIDE, 5MM	-	(1)	(1)	1	(1)	(1)	1	1	SD,SW,U
		82	94101-06000	RONDELLE PLATE, 5MM	-	-	-	-	-	-	8	-	
		83	94103-05800	RONDELLE PLATE, 8MM	-	(4)	(4)	4	(4)	(4)	4	4	CM,E,ED,F,IT
		83	94103-05800	RONDELLE PLATE, 8MM	-	(4)	(4)	4	(4)	(4)	4	4	SD,SW,U
		84	94103-06000	RONDELLE PLATE, 6MM	-	(2)	(2)	2	(2)	(2)	2	2	CM,E,ED,F,IT
		84	94103-06000	RONDELLE PLATE, 6MM	-	(2)	(2)	2	(2)	(2)	2	2	SD,SW,U