

K 13

F-17

Final driven gear

Engrenages de réduction finale

Endabtriebsgetriebe

Engranaje mandado final

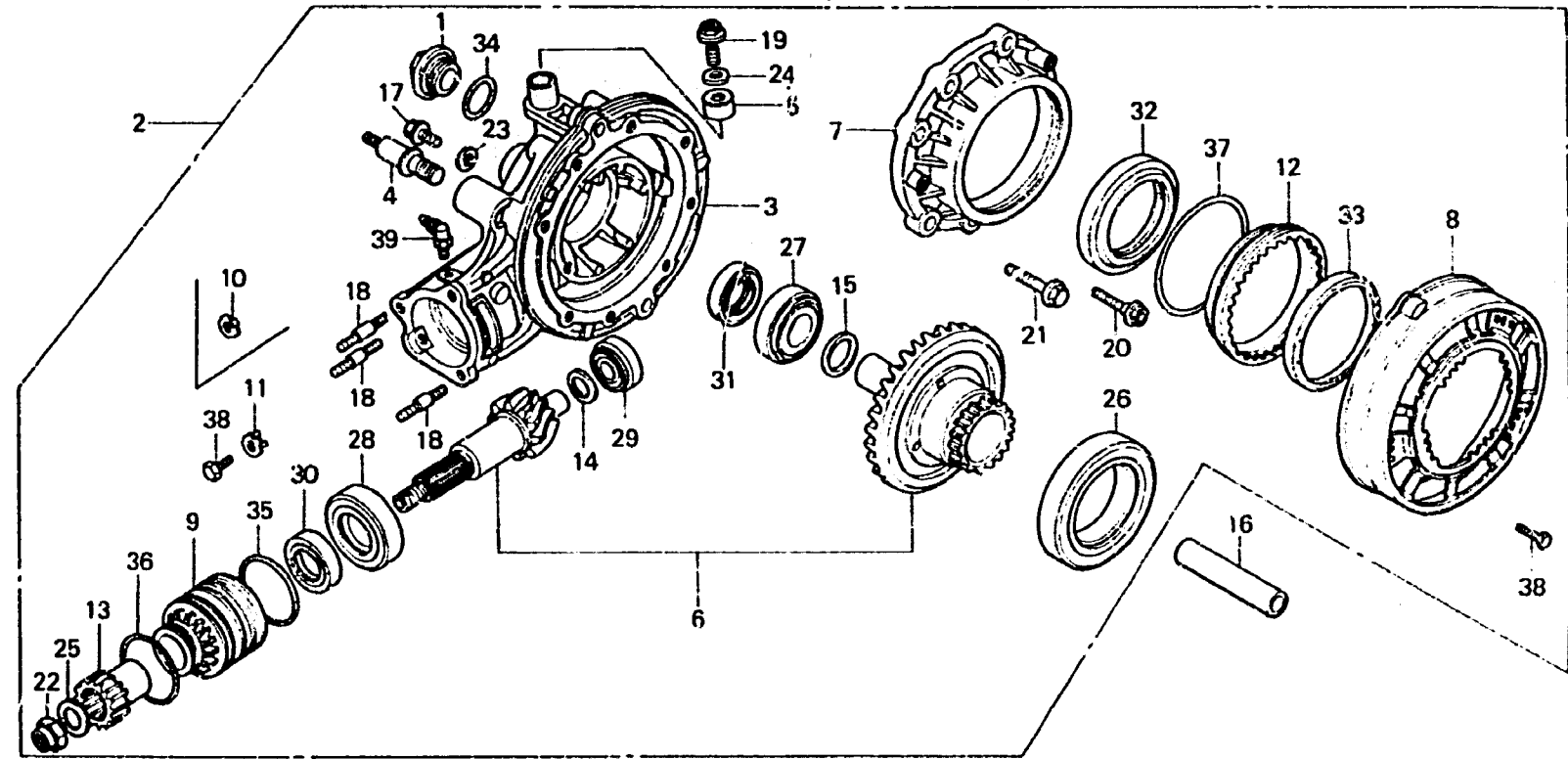

B463-42

Item d'entretien	T.D.R.	N° de réf.	N° de pièce	Description	N° de requis GL1100					N° de série	Code de zone
					A	Ia	Da	a	Ia		
			41458-415-000	CALE I DE PIGNON (1.42)	1	1	1	1	1	1	
			41459-415-000	CALE J DE PIGNON (1.46)	1	1	1	1	1	1	
			41460-415-000	CALE K DE PIGNON (1.50)	1	1	1	1	1	1	
			41461-415-000	CALE L DE PIGNON (1.54)	1	1	1	1	1	1	
			41462-415-000	CALE M DE PIGNON (1.58)	1	1	1	1	1	1	
			41463-415-000	CALE N DE PIGNON (1.62)	1	1	1	1	1	1	
			41464-415-000	CALE O DE PIGNON (1.66)	1	1	1	1	1	1	
			41465-415-000	CALE P DE PIGNON (1.70)	1	1	1	1	1	1	
			41466-415-000	CALE Q DE PIGNON (1.74)	1	1	1	1	1	1	
			41467-415-000	CALE R DE PIGNON (1.78)	1	1	1	1	1	1	