

**C 16**

**E-12**

Oil filter • Oil pan

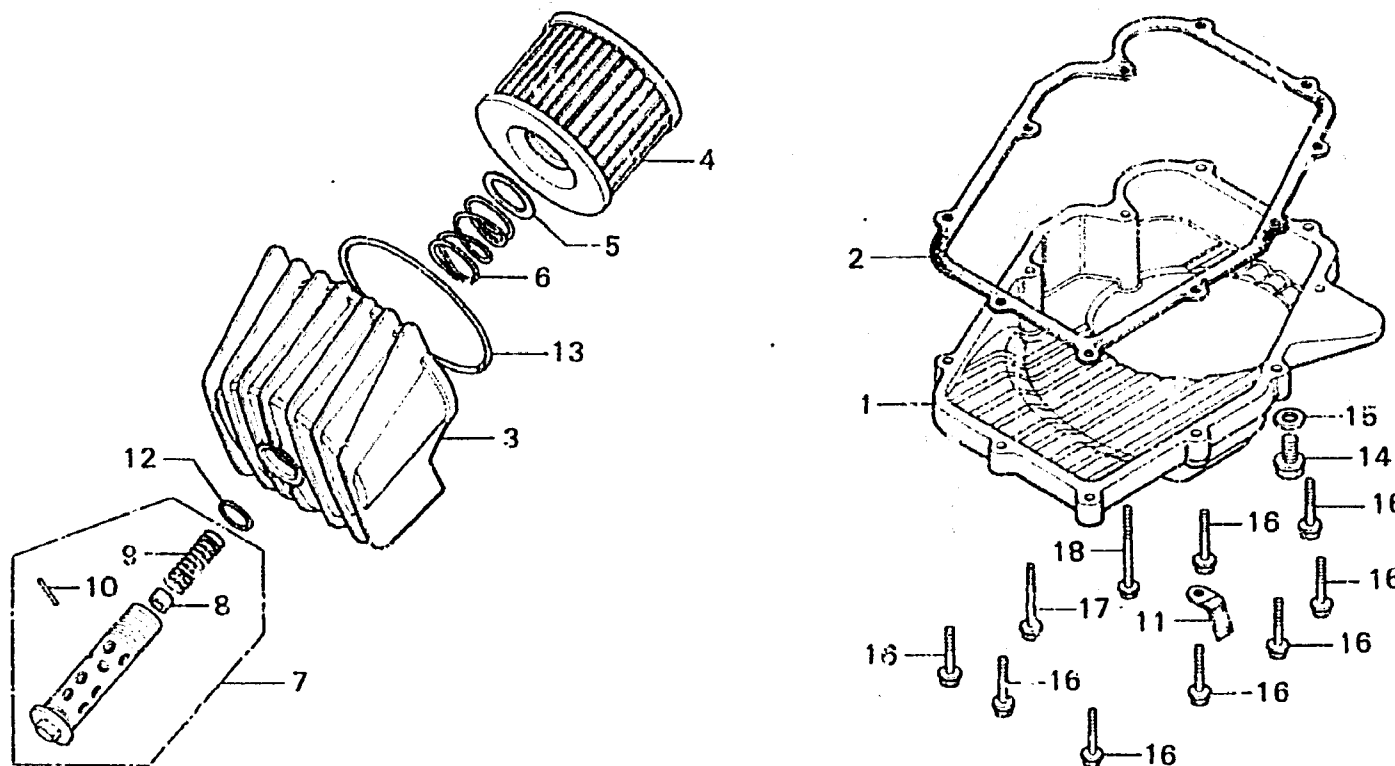

B392-11

Service item	F.R.T.	Ref. No.	Part No.	Description	Reqd. No. CB750K6	Serial No.	Area code
OIL PAN/OIL PAN GASKET	0.8	1	11210-300-050	PAN, OIL	1		
OIL FILTER ELEMENT and its related parts	0.2	2	11398-300-303	GASKET, OIL PAN	1		
		3	15411-300-010	CASE, OIL FILTER	1		
		4	15412-300-024	ELEMENT, OIL FILTER (TOKYO ROKI)	1		
		5	15414-300-000	SEAT, OIL FILTER SPRING	1		
		6	15415-300-000	SPRING, OIL FILTER ELEMENT SET	1		
		7	15420-300-020	BOLT, OIL FILTER CENTER	1		
		8	15473-300-300	VALVE, CHECK	1		
		9	15474-300-310	SPRING, CHECK VALVE	1		
		10	15477-300-300	PIN, SPRING SET	1		
		11	32111-300-000	CLAMPER, CURD	1		
		12	91304-028-000	O-RING, 15X2.5	1		
		13	91316-300-003	O-RING, 89X4.5	1		
			91316-300-005	O-RING, 89X4.5	1		
		14	92800-12000	BOLT, DRAIN PLUG, 12MM	1		
		15	94109-12000	WASHER, DRAIN PLUG, 12MM	1		
		16	95700-06028-00	BOLT, FLANGE, 6X28	8		
		17	95700-06040-00	BOLT, FLANGE, 6X40	1		
		18	95700-06050-00	BOLT, FLANGE, 6X50	1		

1978.02.20

E-12