

I 12

F-21

Step

Repose pieds

Tritt

Estribo

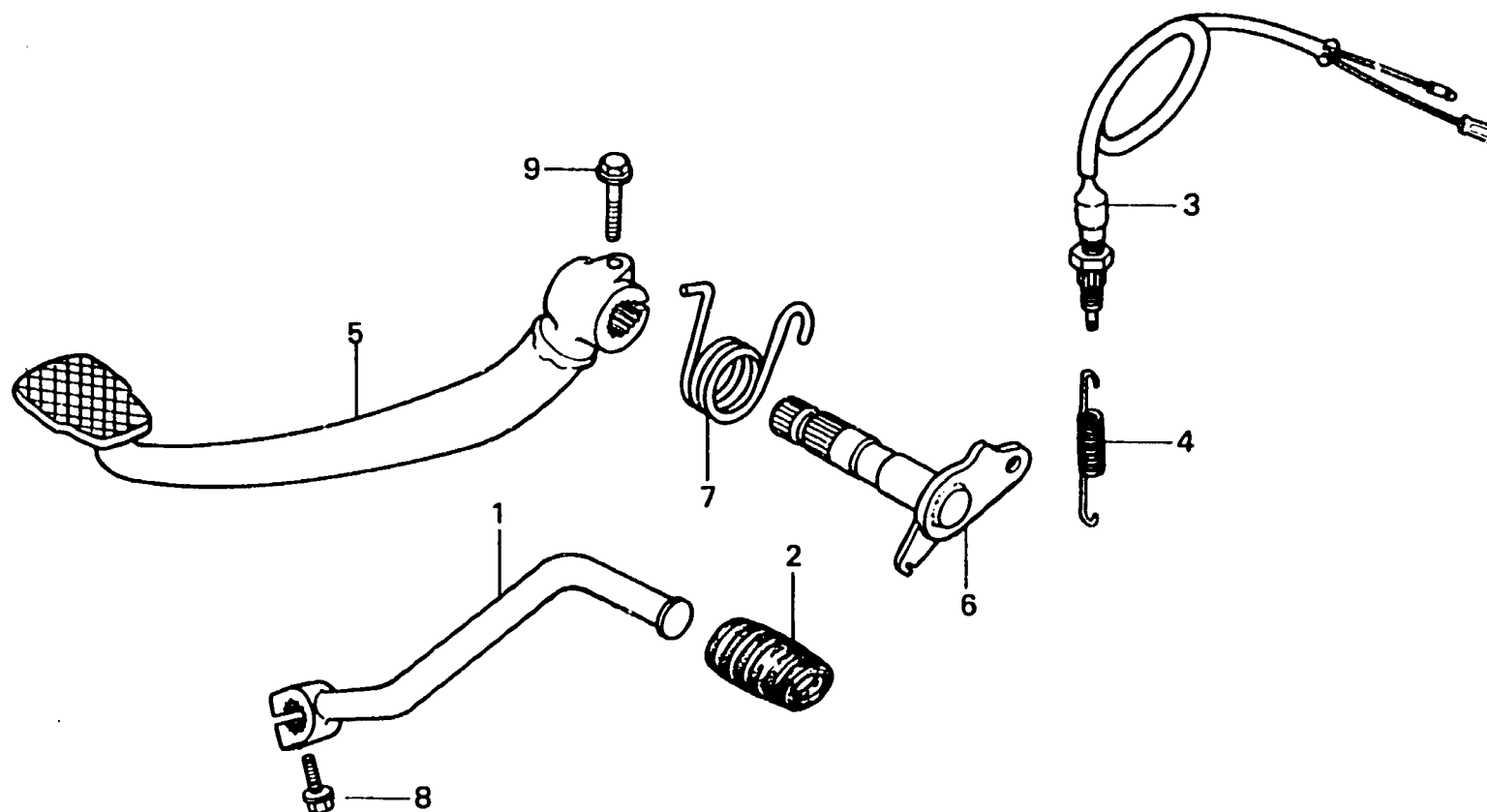

BMC5-21

Item d'entretien	T.D.R.	N° de réf.	N° de pièce	Description	N° de requis CX 400 500	N° de série	Code de zone
ENS. REPOSE PIEDS D. (PIECES RELATIVES Y COMPRISES)	0.1	1	37243-323-000	COLLIER D'INSTALLATION DE COMPTEUR	2 2		
• BARRE DE REPOSE PIEDS G. (PIECES RELATIVES Y COMPRISES)		2	50601-MC5-000	SUPPORT DE REPOSE-PIEDS D.	1 1		
• BARRE MARCHE-PIED SELLE AR. (PIECES RELATIVES Y COMPRISES)		3	50603-033-000	AXE DE JOINT DE REPOSE-PIEDS	2 2		
SUPPORT DE REPOSE-PIEDS D.	0.2	4	50610-MC5-000	ENS. REPOSE PIEDS D.	1 1		
• SUPPORT DE REPOSE-PIEDS G.		5	50611-MC5-000	SUPPORT DE REPOSE PIEDS D.	1 1		
• SUPPORT DE MARCHE-PIED SELLE AR. D.		6	50612-460-840	BARRE DE REPOSE PIEDS D.	2 2		
• SUPPORT DE MARCHE-PIED SELLE AR. G.		7	50614-413-000	RONDELLE DE REPOSE-PIEDS PRINCIPAL	2 2		
		8	50619-460-840	BUTEE DE CAOUTCHOUC DE REPOSE-PIEDS	2 2		
		9	50620-MC5-000	ENS. REPOSE PIEDS G.	1 1		
		10	50621-MC5-000	SUPPORT DE REPOSE PIEDS G.	1 1		
		11	50643-460-840	BARRE DE REPOSE PIEDS G.	1 1		
		12	50661-425-670	CAOUTCHOUC DE REPOSE-PIEDS	2 2		
		13	50700-MC5-000	ENS. REPOSE PIEDS D.	1 1		