

## Changing Final Drive Oil

1. Place your motorcycle on the side stand on a level surface.
2. Place a drain pan under the drain bolt.
3. Remove the oil fill hole cap, O-ring, drain bolt, and sealing washer to drain the oil.

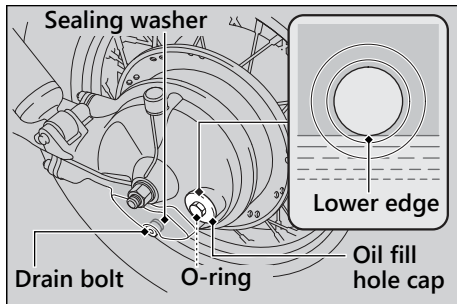

4. Install a new sealing washer onto the drain bolt. Tighten the drain bolt.

**Torque:** 9 lbf-ft (12 N·m, 1.2 kgf·m)

5. Fill the final gear with the recommended oil. ► P. 44

**Required oil:** 5.4 US oz (160 cm<sup>3</sup>)

6. Check the oil level. It should be flush with the lower edge of the oil fill hole.
7. Install a new O-ring onto the oil fill hole cap. Tighten the oil fill hole cap.

**Torque:** 9 lbf-ft (12 N·m, 1.2 kgf·m)

8. Check that there are no oil leaks.