

# Safety Labels

(USA - 49 states, Canada, Australia, New Zealand models)

(USA - 50 states [meets California] models)

**⚠ WARNING**

**SERIOUS INJURY or DEATH can result if you ignore the following: DO NOT RIDE IN CARGO BED. DO NOT OVERLOAD CARGO BED.**

- Overloading can cause loss of control and crash.
- Maximum load (1,000 lbs/454 kg).
- Keep cargo inside the bed, as far forward, centered and as low as possible.
- Secure items to prevent shifting.
- Reduce speed and allow more room to turn or stop.

**⚠ WARNING**

**SERIOUS INJURY or DEATH can result if you ignore the following: DO NOT RIDE IN CARGO BED. DO NOT OVERLOAD CARGO BED.**

- Overloading can cause loss of control and crash.
- Maximum load (600 lbs/272 kg).
- Keep cargo inside the bed, as far forward, centered and as low as possible.
- Secure items to prevent shifting.
- Reduce speed and allow more room to turn or stop.

loading warning

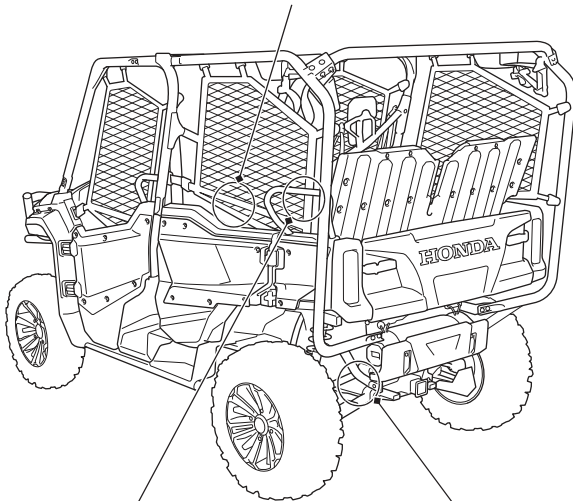

**⚠ WARNING**

**Improper Use of Off-Highway Vehicles Can Cause Severe Injury or Death**

- Only sit in designated seating positions and wear your seatbelt.
- Always wear an approved helmet and protective gear.
- Close doors and latch nets before driving.
- Each rider must be able to sit with back against seat, feet flat on floor, and hands on handholds. Stay completely inside the vehicle.

Read Owner's Manual Follow All Instructions and Warnings

rear passenger warning  
(SXS1000M5P/M5D/M5L only)

**⚠ WARNING**

**Improper towing can result in serious injury or death.**

- Don't exceed the towing capacity.
- When towing, reduce speed, allow more room to turn and stop.
- Read the towing section in the owner's manual.

**Towing Capacity**

- Towing weight limit 2000 lbs. (907 kg)
- Tongue weight limit 200 lbs. (90 kg)

trailer hitch