

# If a Fuse Blows

## Main Fuse Access

1. To prevent an accidental short circuit, turn the ignition switch OFF (w) before checking or replacing the fuses.
2. Remove the front hood (page 137).
3. Remove the fuse box cover.
4. To access the main fuse, remove the bolts, and then pull the main fuse out. If the main fuse is blown, see your dealer for this service.

## UNDER FRONT HOOD

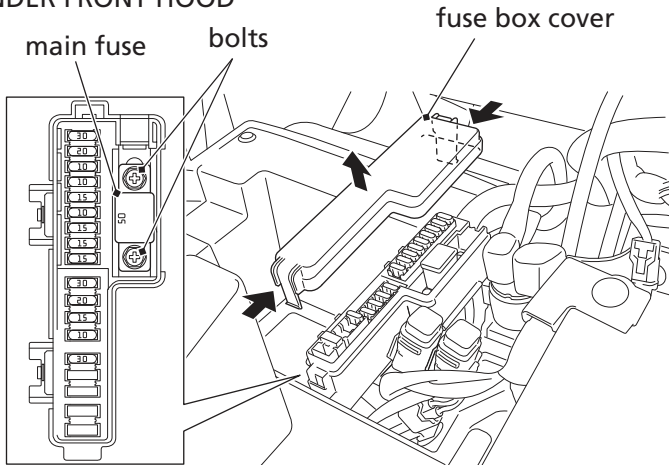

(cont'd)