

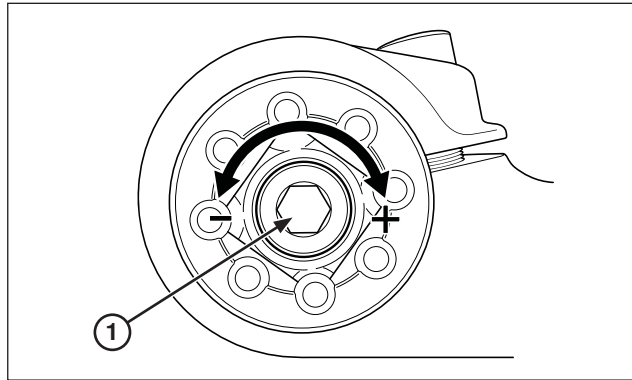

### Front Suspension

#### Inspection

1. Make sure that the fork surfaces and dust seals are clean.
  2. Check for signs of oil leakage. Damaged or leaking fork seals should be replaced before you ride the motorcycle.
  3. Make a quick check of fork operation by locking the front brake and pushing down on the handlebar several times.
- When your 4RIDE is new, break in your 4RIDE to ensure that the suspension has worked in.
  - After break-in, test ride your 4RIDE with the front suspension at the standard setting before attempting any adjustments.



(1) PRE-LOAD ADJUSTER

#### Fork

The motorcycle is shipped with a light coating of grease on the forks. This is not an indication of a leak.

The fork should always be adjusted for the rider's weight and track conditions by using one or more of the following methods.

Basically, there are two adjustments you can make to the front suspension:

- Rebound damping (right fork)  
Turning the rebound damping adjuster adjusts how quickly the fork extends.
- Spring pre-load (left fork)  
Turning the spring pre-load adjuster adjusts the spring initial pre-load length.

Replace the fork fluid every 2 months. See page 4-8, 4-10 for oil level adjustment after changing the fork fluid.

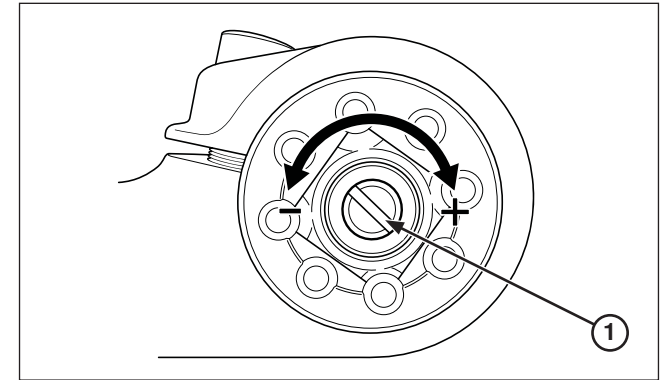

(1) REBOUND ADJUSTER

Use specified fork fluid which additives to assure maximum performance of your 4RIDE's front suspension.

**Specified fork fluid:      Tech OJ 01 (SAE5)**

- Periodically check and clean all front suspension parts to assure top performance. Check the dust seals for dust, dirt and foreign materials. Check the fluid for any contamination.
- Make rebound damping adjustments in one-click increments. Adjusting two or more clicks at a time may cause you to pass over the best adjustment. Test ride after each adjustment.
- If you become confused about adjustment settings, return to the standard position and start over.