

Electrical servicing

Servicing information

- Bear in mind the following when replacing the front headlight bulb.
 - Use clean gloves when replacing the bulb. Do not touch the front headlight bulb with your fingertips, since this could produce hot spots on the bulb and cause it to break.
 - If you touch the bulb with your bare hands, clean it with a cloth moistened with alcohol to prevent its early failure.
- Ensure that you replace the dust cover after changing the front headlight bulb.
- The bulb for the front headlight gets very hot when it is on and remains hot for a while after the front headlight has been turned off. Ensure that you leave it to cool before carrying out any maintenance work.
- Continuity checks can be carried out using the switches on the motorcycle.
- The following colour codes are used throughout this section.

COLOUR CODES	
B	Black
Y	Yellow
L	Blue
G	Green
R	Red
W	White
V	Violet
BR	Brown
O	Orange
SB	Light blue
LG	Light green
P	Pink
GR	Grey

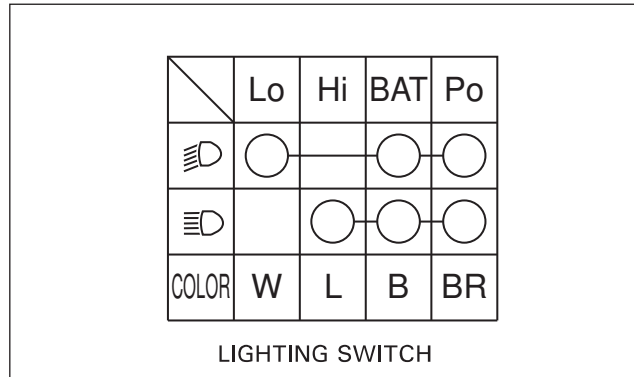

Checks:

If the engine starts but the front headlight or the position light do not work, check the following:

- Bulb blown or not of the specified wattage.
- Loose connector.
-

Start the engine and check the voltage between the following terminals of the connector 9P (white) on the harness side:

Connection: Black (+) – Ground (–)
Standard: 12V approximately.

If there is no voltage, check the following:

- Open circuit in the black wire between the ignition relay and the connector 9P (white) on the handlebar.

If there is voltage, disconnect the connector 9P from the left switch on the handlebar.

Check the continuity between the terminals in each switch position, as shown in the table.

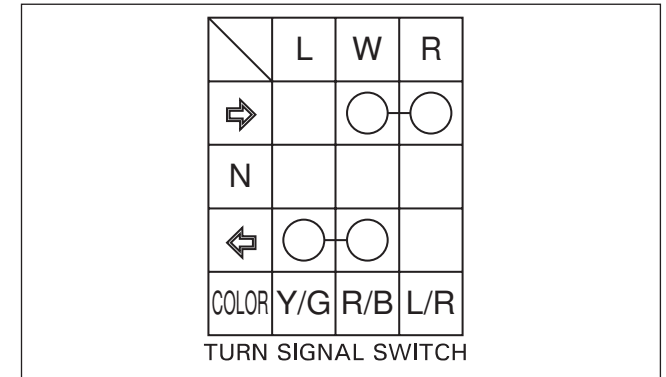

Indicator light/Indicator light relay.

Checks:

If the engine starts but the indicator lights do not work, check the following:

- Bulb blown or not of the specified wattage.
- Loose connector.
- Operation of the indicator light switch:

Remove the housing for the upper headlight.

Disconnect the connector 9P from the left switch on the handlebar.

Check the continuity between the terminals in each switch position, as shown in the table.

If the previous elements are working properly, remove the housing for the upper headlight and disconnect the connector 2P white from the indicator light relay.

Start the engine and check the voltage between the following terminals of the connector on the harness side:

Connection: Red/Black (+) – Ground (–)
Standard: 12V approximately.

If there is no voltage, check the following:

- Open circuit in the Red/Black wire between the indicator light relay 2P (white) and the ignition relay.