

(1) GASKET

Measure the oil pump body clearance.

Standard: 0.15 – 0.20 mm (0.006 – 0.008 in)

Temporarily install the crankcase gasket.

Measure the side clearance using a straight edge and feeler gauge.

Standard: 0.05 – 0.12 mm (0.002 – 0.004 in)

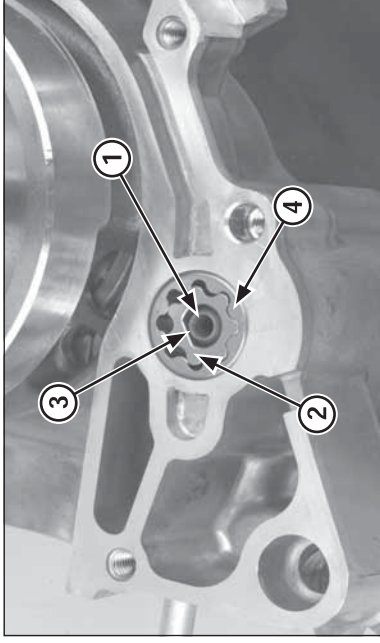

(1) OIL PUMP SHAFT
(2) INNER ROTOR (3) FLAT SURFACES
(4) OUTER ROTOR

Assembly

Apply clean engine oil to the oil pump rotors and shaft.

Install the oil pump shaft into the right crankcase.
Install the inner rotor aligning the flat surface between the rotor and pump shaft.
Install the outer rotor.

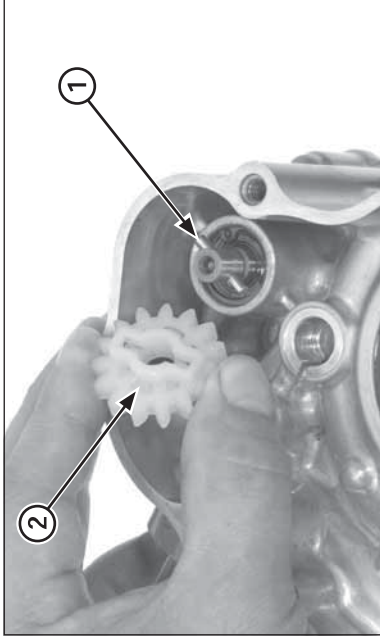

(1) DRIVE PIN
(2) DRIVEN SPROCKET

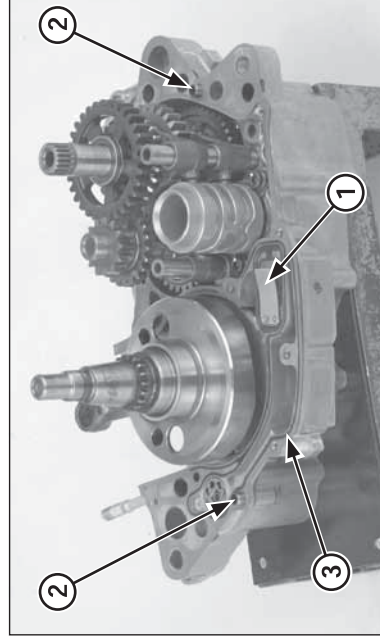

(1) ONE-WAY REED VALVE
(2) DOWEL PINS
(3) NEW GASKET

Install the drive pin into the oil pump shaft hole.
Install the oil pump driven sprocket aligning its groove with the drive pin.

Install the one-way reed valve into the right crankcase.
Note the direction of the reed valve.

Install the dowel pins and new gasket.
Assemble the crankcase.

Install the removed parts in the reverse order of removal.