

6. On the right side, remove the mounting bolts and remove the brake caliper.

- Support the brake caliper assembly so that it doesn't hang from the brake hose. Do not twist the brake hose.
- Avoid getting grease, oil, or dirt on the disc or pad surfaces.
- Do not pull the front brake lever while the brake caliper is removed.
- Take care to prevent the brake caliper from scratching the wheel during removal.

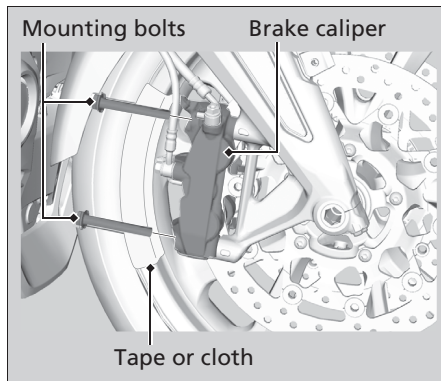

7. Remove the front axle bolt.
8. Loosen the left axle pinch bolts.

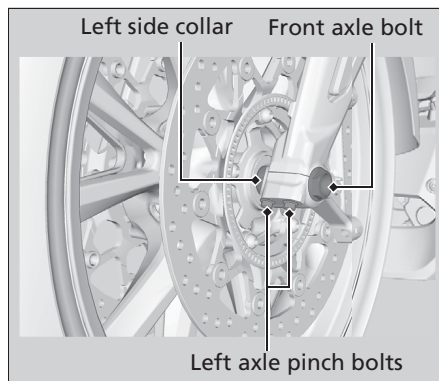

9. Support your motorcycle securely and raise the front wheel off the ground using a maintenance stand or a hoist.
10. Loosen the right axle pinch bolts.
11. On the right side, withdraw the front axle shaft, and remove the side collars and front wheel.

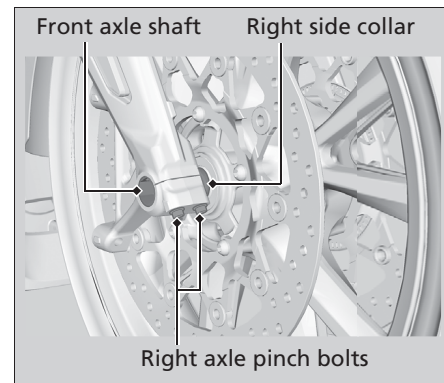

Installation

1. Attach the side collars to the front wheel.
2. On the right side, place the front wheel between the fork legs and insert the lightly greased front axle shaft to the end, through the right fork leg and wheel hub.
3. Align the end of the front axle shaft with the surface of the fork leg.
4. Tighten the right axle pinch bolts to hold the axle.