

Refer to *Important Safety Precautions* on page 31.

Your CRF has a lithium-ion (li-ion) battery. Clean the battery terminals if they become dirty or corroded.

## NOTICE

*An improperly disposed of battery can be harmful to the environment and human health. Always confirm local regulations for proper battery disposal instruction.*

Power of the start button uses current from the battery.

Limited operation also allows the battery to discharge. If you do not ride frequently, we recommend that you charge the battery frequently (see *Battery Charging* on page 134).

If you plan to store your CRF, see *Battery Storage* (this page).

If your battery seems weak and/or is leaking electrolyte (cause slow starting), see your dealer. If you smell an unusual odor coming from the lithium-ion (li-ion) battery, park your CRF in a safe place outside and away from flammable objects, then push and hold the engine stop button until the engine stops completely.

The battery has a limited life span. Consult your dealer about when you should replace the battery. Always replace the battery with another lithium-ion (li-ion) battery of the same type.

The lithium-ion (li-ion) battery contains a fuse inside. If the fuse blows, the battery needs replacement. The voltage may read above 12V even with a blown battery fuse when the battery is unmounted (page 165).

## Battery Storage

Before you remove the battery, be sure to read all the information that follows, as well as the information on the battery label.

## ⚠ WARNING

The battery contains flammable organic solvent as electrolyte.

You can be burned or seriously injured if the battery is handled improperly.

- Keep the battery away from heat, sparks, and flame.
- Keep the battery out of the reach of children.
- Do not disassemble or modify the battery or battery terminals.
- Do not short-circuit the battery with metal tools or other metal objects.
- Do not subject the battery to impacts.

If you do not remove the battery, we recommend disconnecting the battery cables (negative cable first).

The battery is located under the seat.

## Removal

1. Remove the seat (page 43).
2. Remove the battery band (1).
3. Remove the positive terminal cover (2).
4. Disconnect the negative (–) terminal (3) first, then the positive (+) terminal (4) and remove the battery (5).

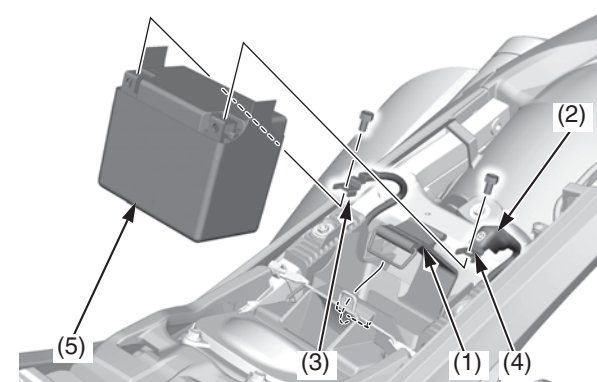

- (1) battery band                      (4) positive (+) terminal  
 (2) positive terminal cover        (5) battery  
 (3) negative (–) terminal

5. Unless you have been riding regularly, charge the battery (page 134).
6. Store your battery in an easy-to-reach location off the floor, in an area protected from freezing temperatures and direct sunlight.
7. Clean the battery box after removing the battery for storage. Dry the battery box.
8. Slow charge the battery (page 134) once every 30 days.

(cont'd)