

- Drain the fork oil by turning the outer tube (1) upside down. (About 0.46 US oz (13.7 cm<sup>3</sup>) of fork oil will be left in the outer tube when it is left inverted for about 20 minutes at 68°F/20°C.)

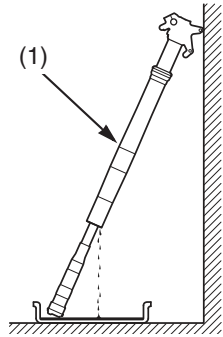

(1) outer tube

Pour the drained oil into a suitable container and dispose of it in an approved manner (page 160).

## NOTICE

*Improper disposal of drained oil is harmful to the environment.*

Amount of fork oil left in the fork (within damper and spring)

unit: cm<sup>3</sup>

minute °C/°F	5	10	20	35	55	85	145
30/86	16.5	14.1	12.7	11.8	11	10.1	8.6
20/68	17.4	15	13.7	12.6	11.5	10.5	9.1
10/50	18.9	16.5	14.8	13.7	12.5	11.4	9.8
0/32	20	18.4	15.9	14.5	13.7	13	11.7

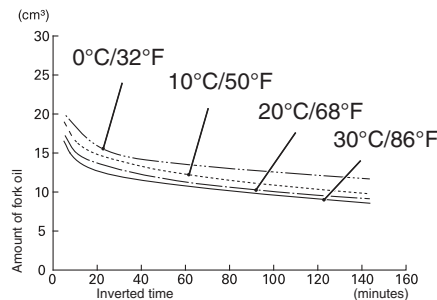

## Fork Oil Refilling

- Pour the recommended fork oil into the outer tube (1).

Be sure the oil capacity is the same in both fork legs.

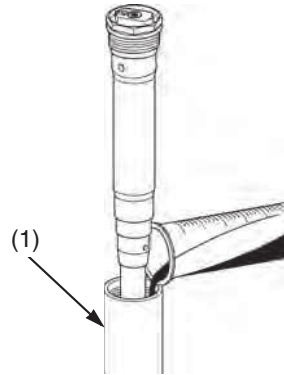

(1) outer tube

Recommended Oil:  
Pro Honda HP Fork Oil, SS-19  
Recommended Standard Amount:  
12.2 US oz (361 cm<sup>3</sup>)

Fill the fork oil which is obtained by docking off the amount of the remaining oil in the fork from the recommended standard fork oil capacity.

Refer to *Front Suspension Adjustments* on page 140.

- Apply the recommended fork oil to a new O-ring (2). Install the O-ring on the fork damper assembly (3).

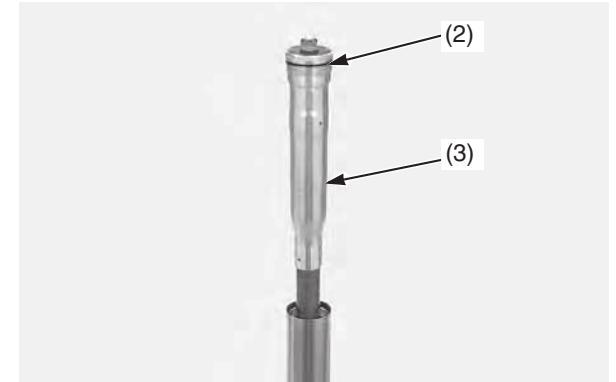

(2) O-ring (new)

(3) fork damper assembly

- Pull up the fork outer tube (1) slowly and temporarily tighten the fork damper assembly (3) using the lock nut wrench (4).

• Lock nut wrench

07WMA-KZ30100

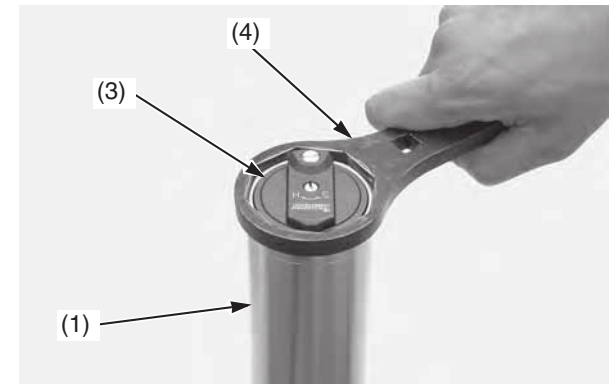

(1) outer tube

(3) fork damper assembly

(4) lock nut wrench