

8. Install the left cylinder head hanger plate (13) and right cylinder head hanger plate (14), then loosely install the cylinder head hanger plate bolts (15) and cylinder head hanger bolts (16). Tighten the cylinder head hanger bolts and cylinder head hanger plate bolts to the specified torque.

cylinder head hanger bolts:  
40 lbf·ft (54 N·m, 5.5 kgf·m)  
cylinder head hanger plate bolts:  
24 lbf·ft (32 N·m, 3.3 kgf·m)

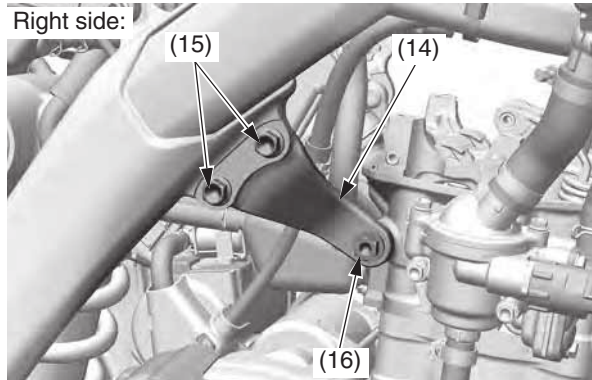
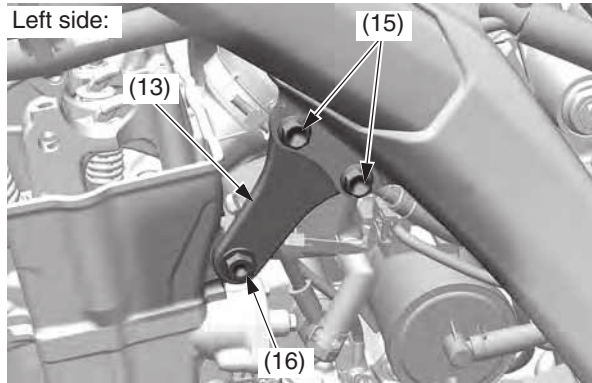

(13) left cylinder head hanger plate  
(14) right cylinder head hanger plate  
(15) cylinder head hanger plate bolts  
(16) cylinder head hanger bolts

9. Install the throttle body (17) to the insulator (18) by aligning the tab of the throttle body with the groove of the insulator and tighten the insulator band screw (19) so the distance between the band ends is  $0.43 \pm 0.04$  in ( $11.0 \pm 1.0$  mm).
10. Connect the vacuum tube (20) to the insulator.

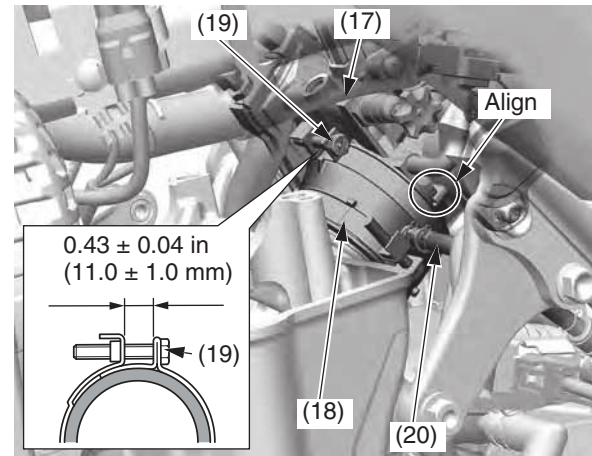

(17) throttle body  
(18) insulator  
(19) insulator band screw  
(20) vacuum tube

11. Install and tighten the right radiator lower mounting bolt (21) and washer (22) securely.

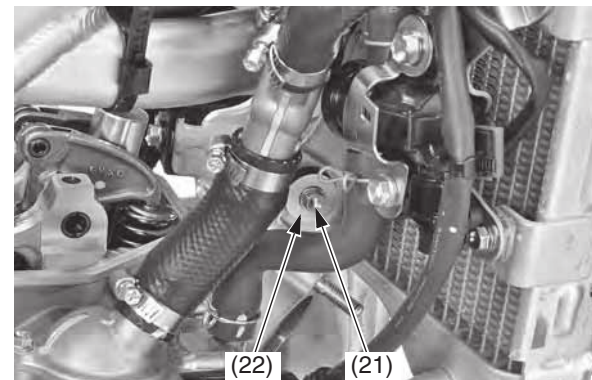

(21) right radiator lower mounting bolt  
(22) washer

12. Install the new O-rings (23) onto the thermostat case dowel pin (24).

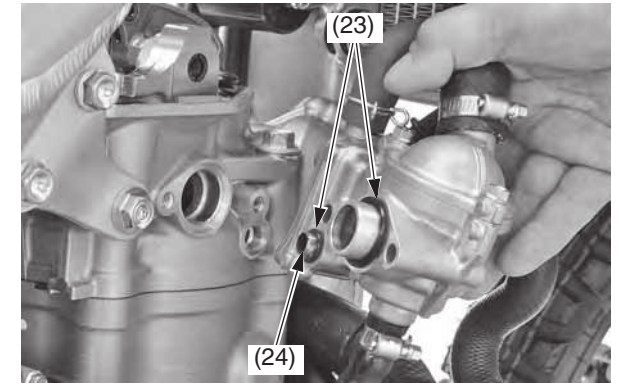

(23) O-rings (new)  
(24) dowel pin

13. Install the thermostat case assembly (25) to the cylinder head (26), then install and tighten the mounting bolts (27) to the specified torque: 7 lbf·ft (10 N·m, 1.0 kgf·m)

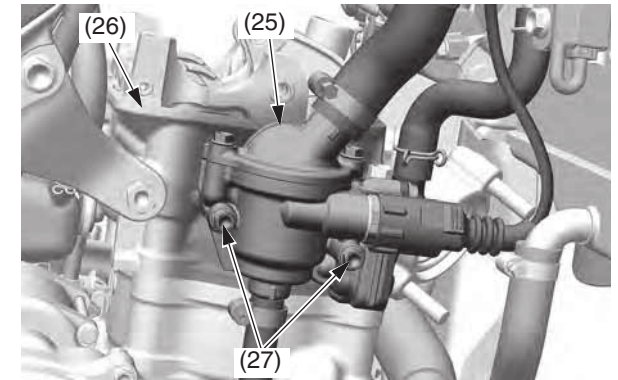

(25) thermostat case assembly  
(26) cylinder head  
(27) bolts

(cont'd)