

7. Make sure that the timing mark (11) on the cam sprocket aligns with the camshaft holder mating surface (12) of the cylinder head.

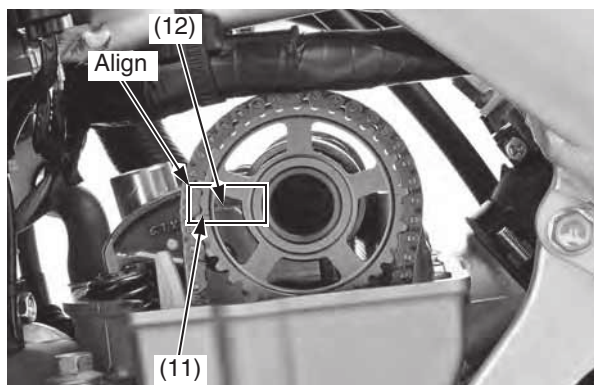

(11) timing mark
(12) camshaft holder mating surface

8. Make sure that the dowel pins (13) are installed into the camshaft holder (14).

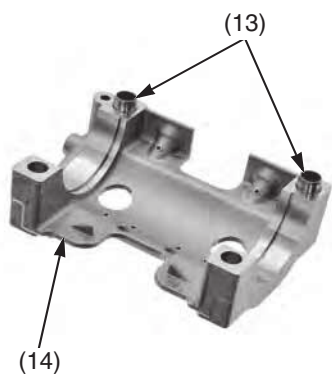

(13) dowel pins (14) camshaft holder

9. Install the set rings (15) on the camshaft bearing grooves (16).

NOTICE

Do not let the set rings fall into the crankcase.

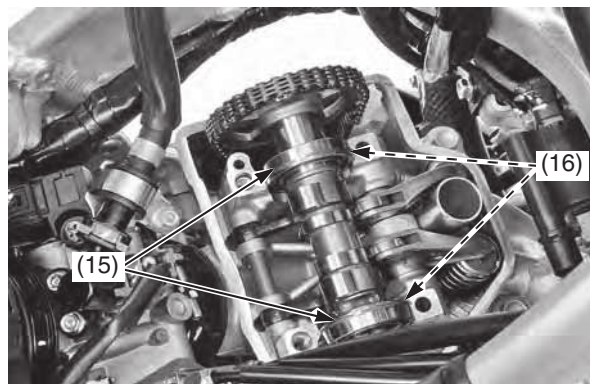

(15) set rings
(16) camshaft bearing grooves

10. Apply engine oil to the camshaft holder bolt threads. Install the camshaft holder (17) with the “ Δ ” mark (18) facing forward. Install the camshaft holder bolts (19) (20) and tighten the camshaft holder bolts to the specified torque:
11 lbf·ft (15 N·m, 1.5 kgf·m)

Tighten the camshaft holder bolts in a crisscross pattern in two or three steps.

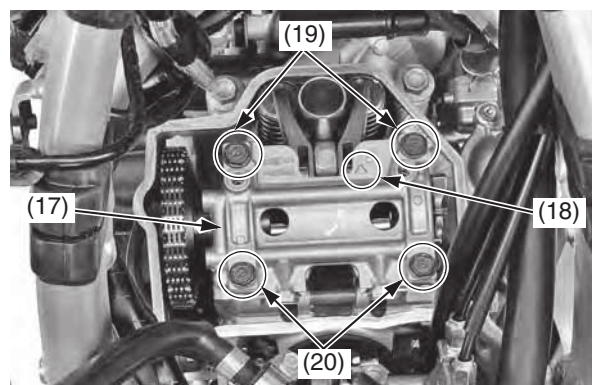

(17) camshaft holder (19) camshaft holder bolts (long)
(18) “ Δ ” mark (20) camshaft holder bolts (short)

11. Remove the tensioner stopper (21) from the cam chain tensioner lifter.

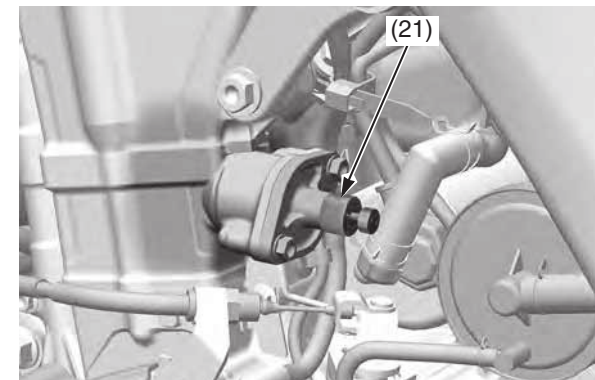

(21) tensioner stopper

12. Make sure that the piston is at TDC on the compression stroke (page 82). Check that the timing mark (11) on the cam sprocket aligns with the camshaft holder mating surface (12) of the cylinder head.

If the timing mark doesn't align with the camshaft holder mating surface, insert the tensioner stopper into the cam chain tensioner lifter (page 84) and then remove the cam chain and realign the timing mark.

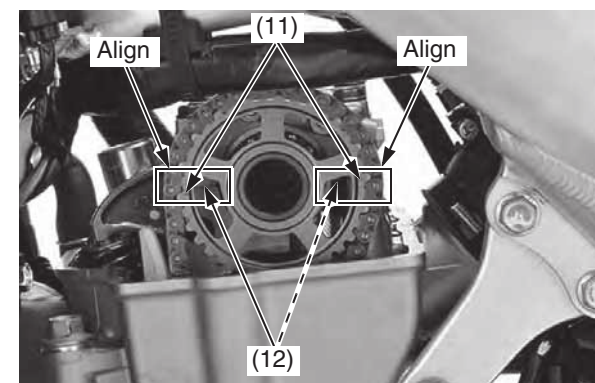

(11) timing mark
(12) camshaft holder mating surface

(cont'd)