

If a Fuse Blows

All of the electrical circuits on your CRF have a fuse to protect them from damage caused by excess current flow (short circuit or overload).

If something electrical on your CRF stops working, the first thing you should check for is a blown fuse (1). Determine from the chart on the circuit fuse box cover which fuse or fuses control that component. Check the fuse before looking elsewhere for another possible cause of the problem. Replace a blown fuse and check component operation.

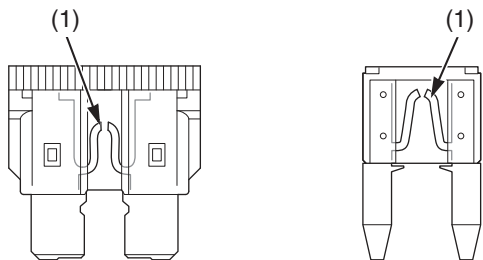

(1) blown fuse

The main fuse and circuit fuses are located on the behind the left side cover.

Recommended Fuses

Main fuse	20 A
Other fuses	10 A

1. To prevent an accidental short circuit, stop the engine.
2. Remove the seat (page 43).
3. Remove the left side cover (page 44).
4. Open the rubber fuse box cover (2) and fuse box cover (3).
5. Pull out the fuses one by one to check for a blown fuse. Always replace a blown fuse with a spare fuse (4) of the same rating.

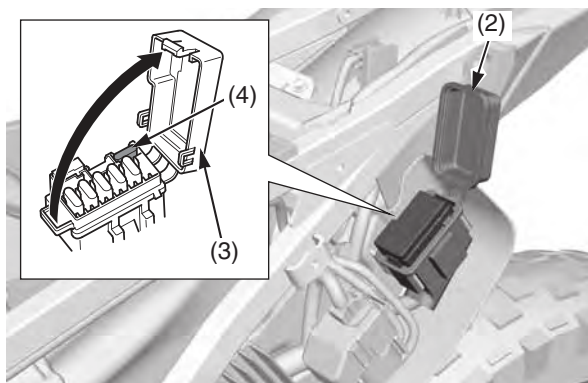

- (2) rubber fuse box cover
(3) fuse box cover
(4) spare fuse

6. Close the fuse box cover and rubber fuse box cover.
7. Install the left side cover (page 44).
8. Install the seat (page 43).

If you do not have a replacement fuse with the proper rating for the circuit, install one with a lower rating.

NOTICE

Replacing a fuse with one that has a higher rating greatly increases the chance of damage to the electrical system.

Main Fuse Access:

1. To prevent an accidental short circuit, stop the engine.
2. Remove the seat (page 43).
3. Remove the left side cover (page 44).
4. Remove the start magnetic switch cover (5).
5. Pull out the main fuse (6) to check for a blown fuse. Always replace a blown fuse with a spare main fuse (7).

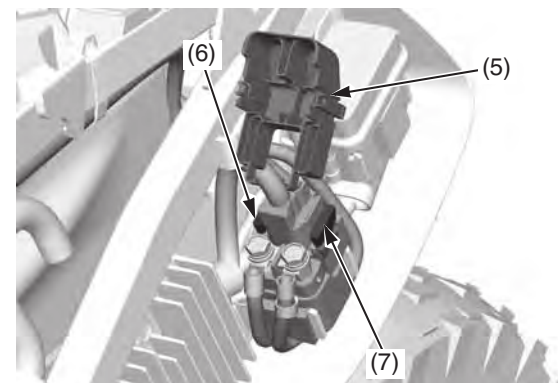

- (5) start magnetic switch cover
(6) main fuse
(7) spare main fuse

6. Close the start magnetic switch cover.
7. Install the left side cover (page 44).
8. Install the seat (page 43).

If you do not have a replacement fuse with the proper rating for the circuit, install one with a lower rating.

NOTICE

Replacing a fuse with one that has a higher rating greatly increases the chance of damage to the electrical system.

If you replace a blown fuse with a spare fuse that has a lower rating, replace the fuse with the correct rating as soon as you can. Also remember to replace the spare fuse that was installed.

If the replacement fuse of the same rating burns out in a short time, there is probably a serious electrical problem on your motorcycle. Leave the blown fuse in that circuit and have your motorcycle checked by your dealer.