

# Suspension

17. Blow out any oil from the oil hole (9) of the fork damper assembly (4) using compressed air.  
Wipe off the oil completely from the fork damper.
18. If you cannot use compressed air, remove the fork air pressure release screws (11) from the fork bolt assembly.  
Hold the fork damper upside down for 20 minutes and drain the fork oil.  
Apply recommended fork oil to a new O-ring (12), and then install a new O-rings on the air pressure release screws (11).  
Tighten the air pressure release screws to the specified torque:  
1.0 lbf·ft (1.3 N·m, 0.1 kgf·m)

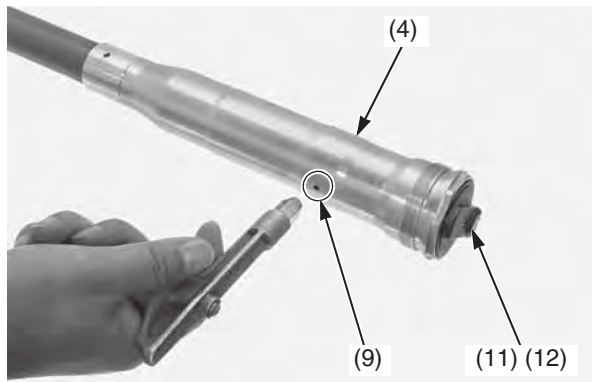

(4) fork damper assembly  
(9) oil hole  
(11) air pressure release screws  
(12) O-rings (new)

19. Fully stroke the piston rod (2) by pushing down the fork damper assembly (4).  
Check the piston rod for smooth operation.  
If the piston rod operation is not smooth, check the piston rod for bends or damage.

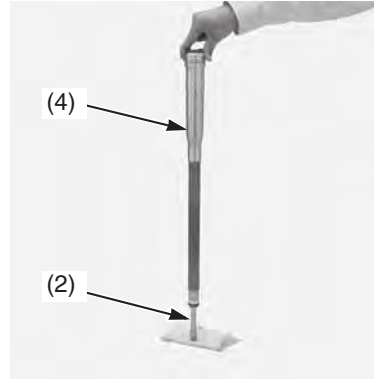

(2) fork damper piston rod  
(4) fork damper assembly

## Fork Damper Installation

1. Drain the fork oil from the fork assembly (1) by placing it upside down.  
(About (0.2 US oz (5.4 cm<sup>3</sup>) of fork oil will be left in the fork assembly when it is left inverted for about 20 minutes at 20 °C/68 °F)

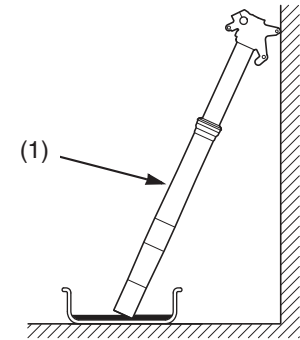

(1) fork assembly

To properly dispose of drained fluids, refer to *You & the Environment* on page 160.

### NOTICE

*Improper disposal of drained fluids is harmful to the environment.*

Amount of fork oil left in the fork (without damper and spring) unit: cm<sup>3</sup>

minute °C/°F	5	10	20	35	55	85	145
30/86	6.5	5.7	5.2	4.5	4.1	3.7	3.3
20/68	6.7	6.2	5.4	4.7	4.4	3.8	3.5
10/50	7.3	6.4	5.6	5	4.6	4.2	3.8
0/32	8.6	8.2	7.9	7.6	7.3	6.8	6