

Valve Clearance Inspection

1. Set the piston at TDC on the compression stroke (page 82).
2. Measure the intake valve clearances by inserting a feeler gauge (1) between the intake rocker arms (2) and camshaft cam lobes (3).

NOTICE

Be careful not to damage the intake rocker arms.

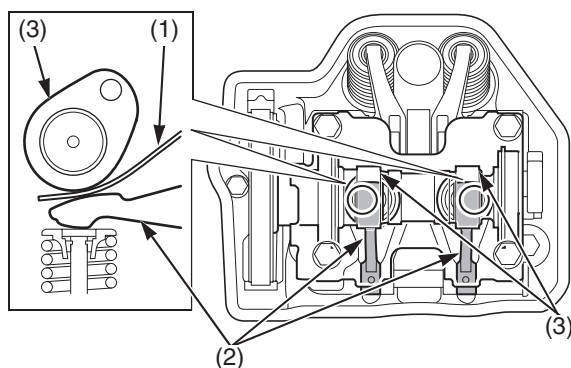
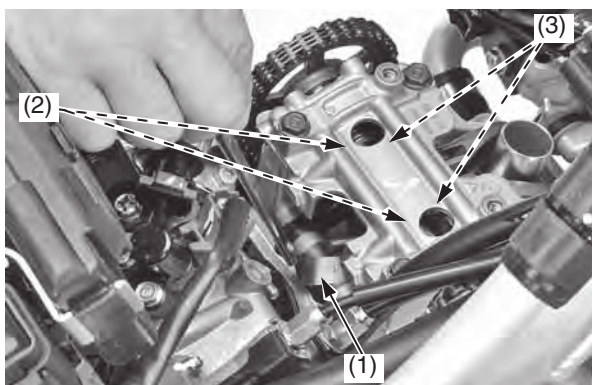

- (1) feeler gauge
(2) intake rocker arms
(3) camshaft cam lobes

Valve Clearance:

IN: 0.004 ± 0.001 in (0.11 ± 0.03 mm)

3. Measure the exhaust valve clearances by inserting a feeler gauge (1) between the exhaust rocker arms (4) and shims (5).

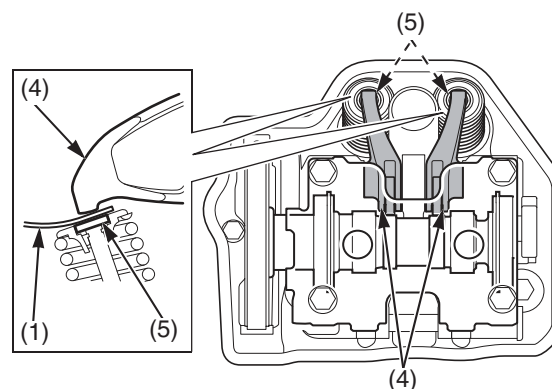
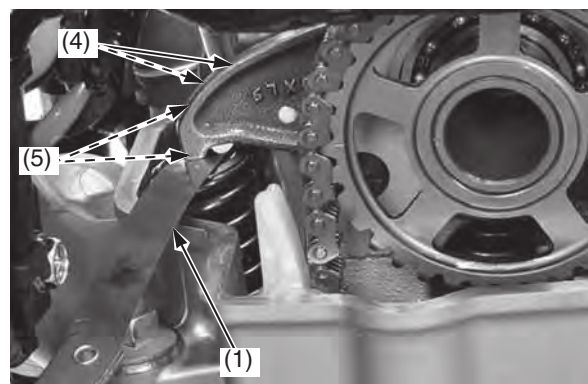

- (1) feeler gauge
(4) exhaust rocker arms
(5) valve shims

Valve Clearance:

EX: 0.011 ± 0.001 in (0.28 ± 0.03 mm)

If intake valve clearance and exhaust valve clearance need adjustment, see Camshaft Removal (this page) and select the correct shim for each valve.

Camshaft Removal

1. Record the intake valve and exhaust valve clearances (this page).
Make sure the piston is at TDC on the compression stroke (page 82).
2. Remove the cam chain tensioner lifter cover bolt (1) and sealing washer (2).

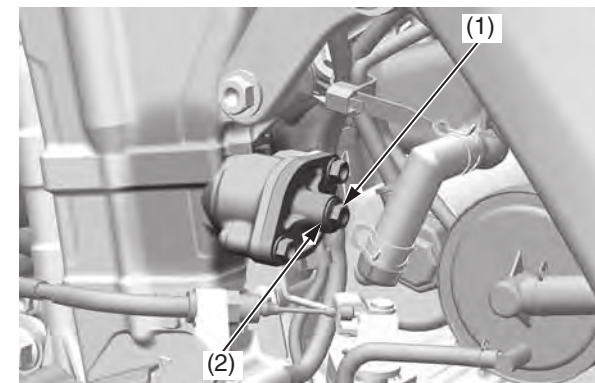

- (1) cam chain tensioner lifter cover bolt
(2) sealing washer

(cont'd)