

Rear Suspension Adjustments

On-Road Use only

The rear suspension can be adjusted for the rider's weight and riding conditions by changing the rebound and compression damping.

Off-Road Use only

The rear suspension can be adjusted for the rider's weight and riding conditions by changing the spring pre-load and the rebound and compression damping.

The rear suspension assembly includes a damper unit that contains high pressure nitrogen gas. Do not attempt to disassemble, service, or dispose of the damper; see your dealer. The instructions found in this owner's manual are limited to adjustments of the shock assembly only.

Puncture or exposure to flame may also result in an explosion, causing serious injury. Service or disposal should only be done by your dealer or a qualified mechanic, equipped with the proper tools, safety equipment and an official Honda Service Manual.

Off-Road Use only

If your motorcycle is new, put enough part-throttle break-in time (about 1 hour) on it to ensure that the suspension has worked in.

Rear Suspension Spring Pre-Load (Off-Road Use Only)

Pre-load should be adjusted when the engine is cold because it is necessary to remove the muffler. An optional pin spanner is available for turning the shock spring lock nut and adjusting nut to adjust spring pre-load.

1. Place your motorcycle on an optional workstand or equivalent support with the rear wheel off the ground.
2. Remove the subframe (page 52).
3. Check that the spring pre-load is adjusted to the standard length. Adjust as necessary by loosening the shock spring lock nut (1) and turning the adjusting nut (2).

Each complete turn of the adjusting nut changes the spring length by 0.06 in (1.5 mm). After adjustment, hold the adjusting nut and tighten the shock spring lock nut to the specified torque:
32 lbf·ft (44 N·m, 4.5 kgf·m)

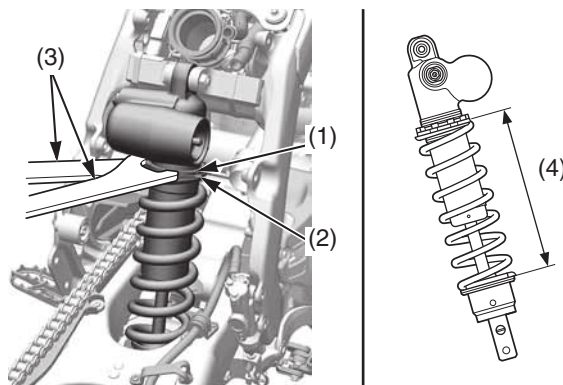

(1) shock spring lock nut (2) adjusting nut (3) pin spanners (4) spring length

Refer to the following pages for the installation procedure of the removed parts:

- air cleaner housing and air cleaner connecting tube: page 58 (Cylinder Head Installation)
- subframe: page 55

To increase spring pre-load

Loosen the shock spring lock nut with the optional pin spanners (3) and turn the adjusting nut to shorten the spring length (4). Do not shorten to less than:

8.88 in (225.5 mm)

To decrease spring pre-load

Loosen the shock spring lock nut with the optional pin spanners (3) and turn the adjusting nut to increase the spring length (4). Do not increase to more than:

9.41 in (239.0 mm)

Each turn of the adjusting nut changes spring length and spring pre-load. One turn equals: spring length/spring pre-load:
Standard: 0.06 in (1.5 mm)/18 lbf (78 N)

Pin spanners should be used for turning the shock spring lock nut and adjusting nut. See page 190 for optional pin spanners.

Spring pre-load length

Standard: 9.13 in (232.0 mm)
Max. : 9.41 in (239.0 mm)
Min. : 8.88 in (225.5 mm)