

Spark Arrester Inspection

The spark arrester must be serviced every 1,000 mi (1,600 km) of running or 100 operating hours to maintain its efficiency.

Regular servicing prevents carbon buildup (which can diminish engine performance) and also complies with USDA regulations for regular maintenance to assure proper function.

The spark arrester prevents random sparks from the combustion process in your engine from reaching the environment.

1. Allow the engine and muffler (1) to cool.
2. Remove the tail cap cover bolts (2), washers (3) and tail cap cover (4) from the muffler.

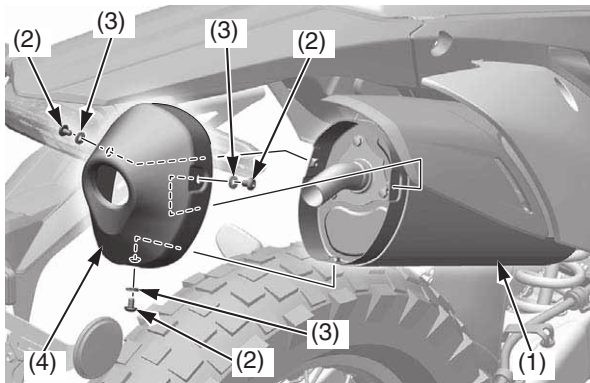

- (1) muffler
- (2) tail cap cover bolts
- (3) washers
- (4) tail cap cover

3. Remove the spark arrester mounting bolts (5), spark arrester (6) and gasket (7) from the muffler (1).

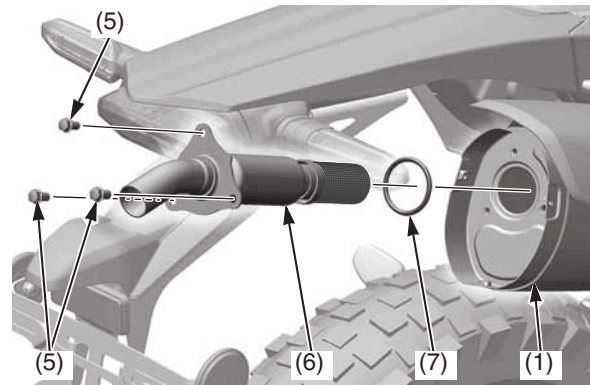

- (1) muffler
- (5) spark arrester mounting bolts
- (6) spark arrester
- (7) gasket

4. Use a brush to remove carbon deposits from the spark arrester screen. Be careful to avoid damaging the spark arrester screen (8). The spark arrester must be free of breaks and holes. Replace, if necessary. Check the gasket. Replace, if necessary.

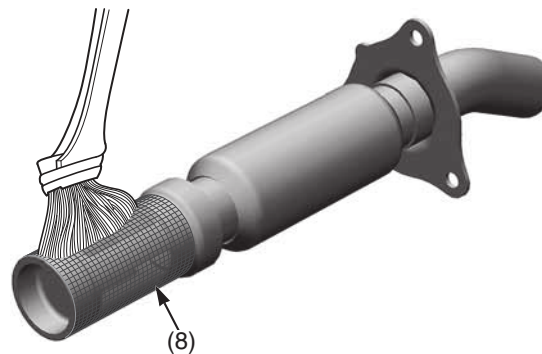

- (8) spark arrester screen

5. Install a new gasket (7) and the spark arrester (6) in the muffler (1) and tighten the spark arrester mounting bolts (5) to the specified torque:
6.6 lbf·ft (9.0 N·m, 0.9 kgf·m)

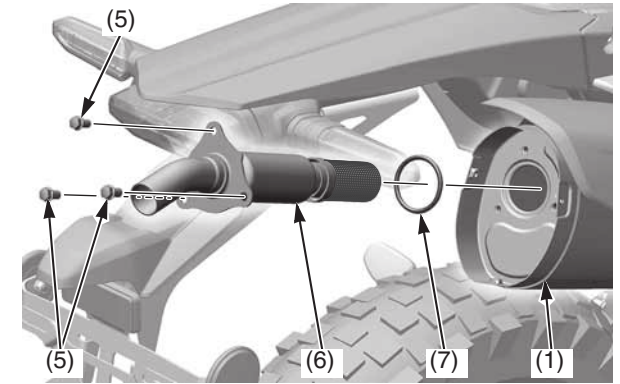

- (1) muffler
- (5) spark arrester mounting bolts
- (6) spark arrester
- (7) gasket

6. Install the tail cap cover (4), washers (3) and tighten the tail cap cover bolts (2) to the specified torque:
3.9 lbf·ft (5.25 N·m, 0.5 kgf·m)

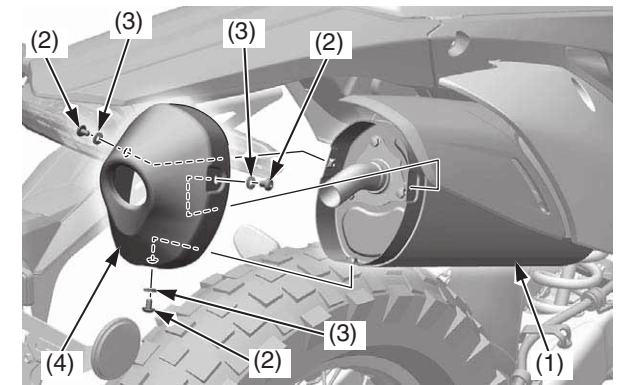

- (1) muffler
- (2) tail cap cover bolts
- (3) washers
- (4) tail cap cover