

Suspension

6. Make the mechanic's stopper tool out of a thin piece of steel (0.08 in (2.0 mm) thick) as shown if you do not have a special tool.

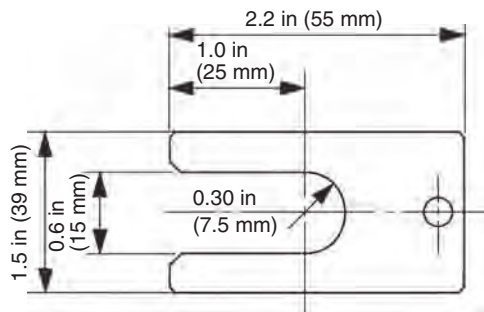

7. Hold the fork center bolt lock nut (3) and remove the fork center bolt (2) from the fork damper.

NOTICE

Do not remove the lock nut from the fork damper piston rod. If the lock nut is removed, the piston rod will fall in the fork damper and you may not reassemble the fork damper.

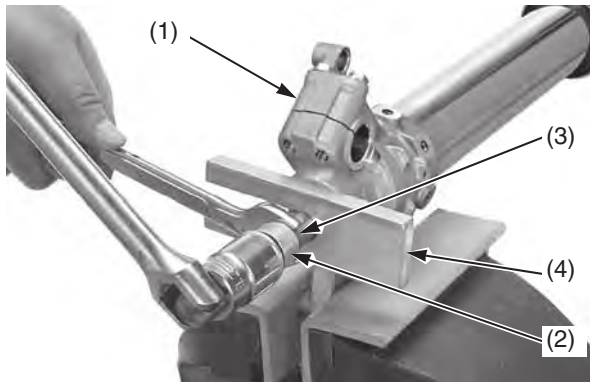

- (1) axle holder
(2) fork center bolt
(3) fork center bolt lock nut
(4) piston base

8. Remove the push rod (5) from the fork damper.
9. Remove the piston base (4) or mechanic's stopper tool between the axle holder (1) and fork center bolt lock nut (3) while pushing the fork outer tube.

NOTICE

Be careful not to damage the lock nut and fork center bolt hole.

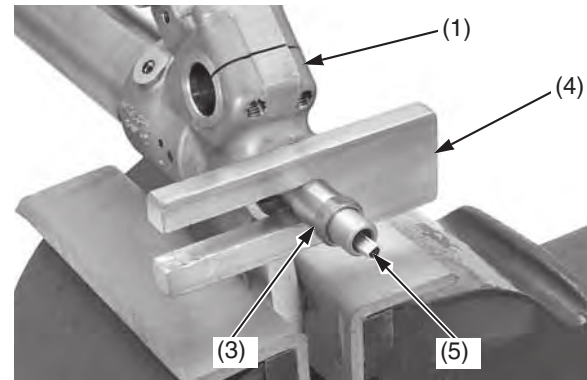

- (1) axle holder
(3) fork center bolt lock nut
(4) piston base
(5) push rod

10. Remove the fork damper assembly (6) from the fork assembly (7).
Remove the fork from the vise.
Remove the fork spring (8), spring seat collar (9) and back-up ring/seat stopper (10) from the fork assembly.

NOTICE

*Do not attempt to separate the fork assembly and drop the axle holder out from the outer tube, which can damage the guide bushings (11).
To avoid damage, hold both the outer tube and slider.*

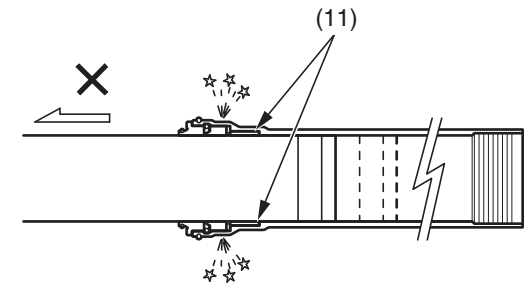

- (11) guide bushing

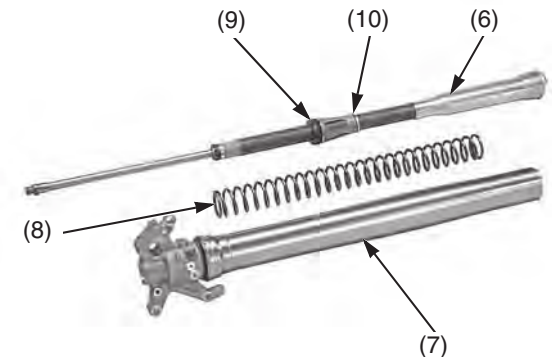

- (6) fork damper assembly
(7) fork assembly
(8) fork spring
(9) spring seat collar
(10) back-up ring/seat stopper