

# Fuel System

3. Remove the fuel pump unit (8), dust seal (9) and O-ring (10).

Be careful not to damage the fuel pump unit and reserve sensor.

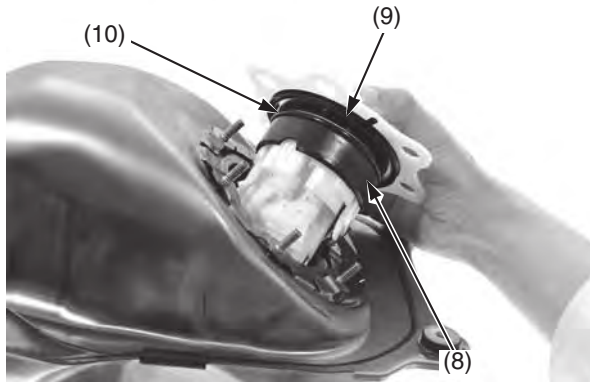

(8) fuel pump unit  
(9) dust seal  
(10) O-ring

4. Disconnect the fuel pump wire terminals (11) and fuel reserve sensor wire terminals (12) from the fuel pump base (13).

Be careful not to damage the wires when disconnecting the fuel reserve sensor wire terminals and fuel pump wire terminals.

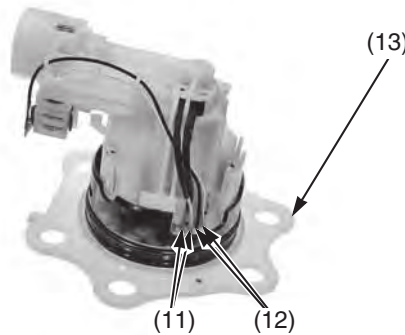

(11) fuel pump wire terminals  
(12) reserve sensor wire terminals  
(13) fuel pump base

5. Check the hooks (14) of the fuel pump unit holder and tabs (15) on the fuel pump base for damage or discoloration. If the hooks and tabs are damaged or discolored, replace the fuel pump unit as an assembly.
6. Release the hooks of the fuel pump unit holder from the grooves (16) in the fuel pump base tabs while pushing the holder against the base and slightly spreading the base tabs.

Be careful not to damage the hooks and tabs.

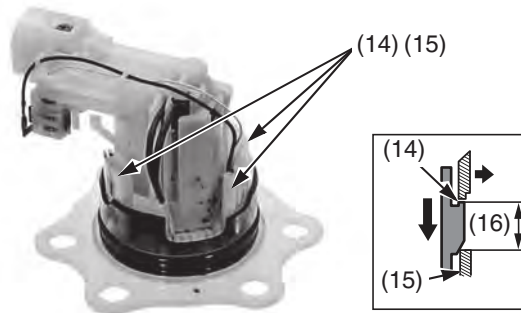

(14) hooks  
(15) tabs

(16) grooves

7. Remove the fuel pump unit holder assembly (17) from the fuel pump base (13) and remove the O-ring (18).

Wipe the spilled out fuel immediately.

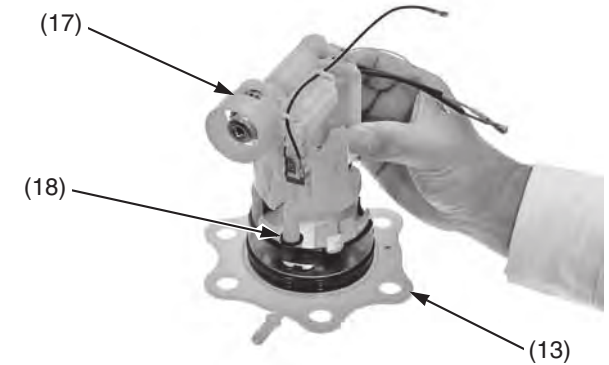

(13) fuel pump base  
(17) fuel pump unit holder assembly  
(18) O-ring

8. Remove the fuel pump stopper (19) and damper rubber (20).



(19) fuel pump stopper  
(20) damper rubber