

12. Clean the surfaces where the axle and axle clamps contact each other.

Apply grease to each dust seal lips (19) of the front wheel.

Install the left side collar (20) and right side collar (21) into the wheel hub.

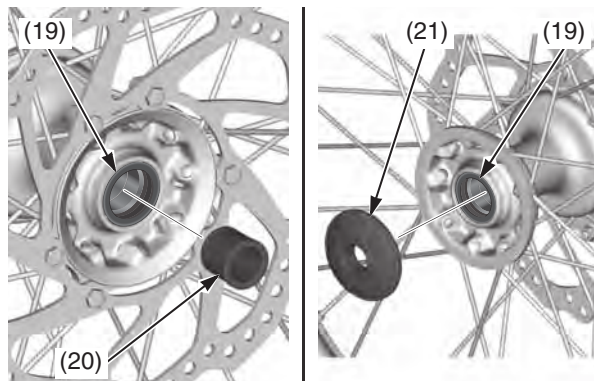

(19) dust seal lips
(20) left side collar

(21) right side collar

13. Install the front wheel between the fork legs while inserting the disc between the pads, being careful not to damage the pads.

14. Insert the front axle shaft (22) through the forks and wheel hub from the right side. Make sure that the front axle shaft is seated firmly onto the left fork leg clamp inner surface. Tighten the front axle nut (23) to the specified torque:

65 lbf-ft (88 N·m, 9.0 kgf·m)

Tighten the left axle pinch bolts (24) to the specified torque:

15 lbf-ft (20 N·m, 2.0 kgf·m)

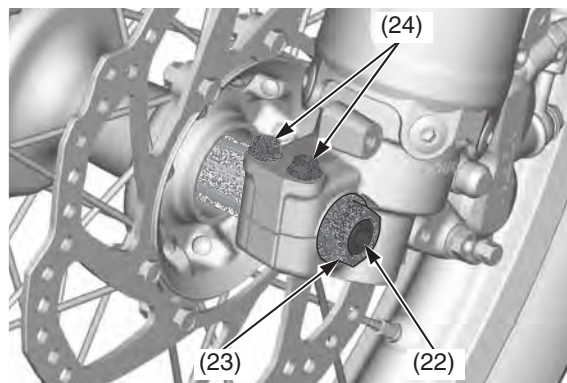

(22) front axle shaft
(23) front axle nut
(24) left axle pinch bolts

15. Install the handlebar (25), mounting rubbers, washers and handlebar lower holder nuts (26) and tighten the handlebar lower holder nuts to the specified torque:

32 lbf-ft (44 N·m, 4.5 kgf·m)

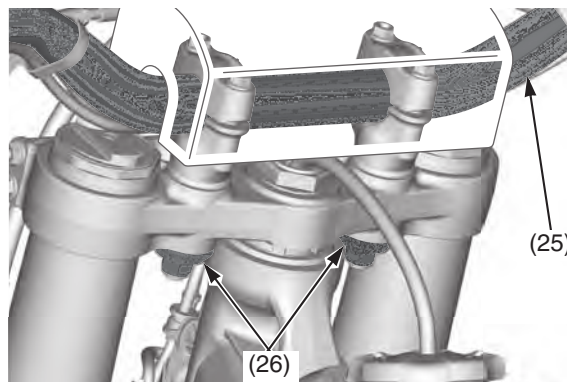

(25) handlebar
(26) mounting rubbers, washers and handlebar lower holder nuts

16. Install the number plate (27) by aligning its tab (28) with the slit (29) on the front fender.

Install the number plate bolts (30), then tighten the number plate bolts to the specified torque: 7 lbf-ft (10 N·m, 1.0 kgf·m)

Route the number plate tab (31) around the handlebar (32) as shown. Make sure that the brake hose (13) is routed properly in front of the number plate.

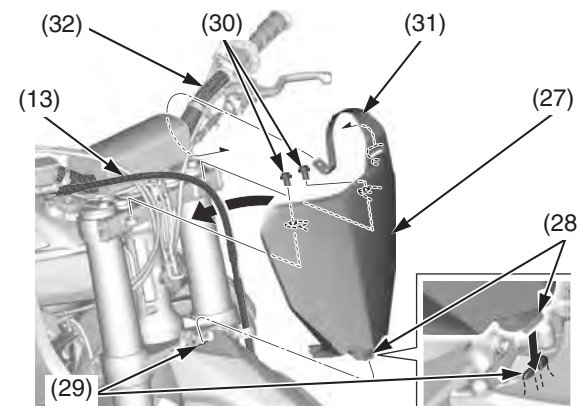

(13) brake hose
(27) number plate
(28) tab
(29) slit

(30) number plate bolts
(31) number plate tab
(32) handlebar

17. With the front brake applied, pump the fork up and down several times to seat the axle and check front brake operation.

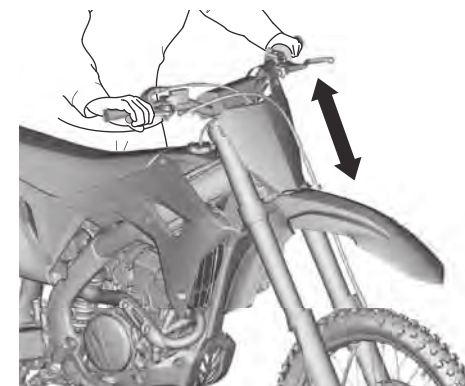

(cont'd)