

## Changing Engine Oil & Filter

Changing the oil and filter requires special tools. We recommend that you have your motorcycle serviced by your dealer.

Use a new Honda Genuine oil filter or equivalent specified for your model.

### NOTICE

Using the wrong oil filter can result in serious damage to the engine.

1. Remove the under cowl. ► P. 57
2. If the engine is cold, idle the engine for 3 to 5 minutes.
3. Turn the ignition switch to the OFF position and wait for 2 to 3 minutes.
4. Place your motorcycle on a firm, level surface.

5. Place a drain pan under the drain bolt.
6. Remove the oil fill cap, drain bolt, and sealing washer to drain the oil.

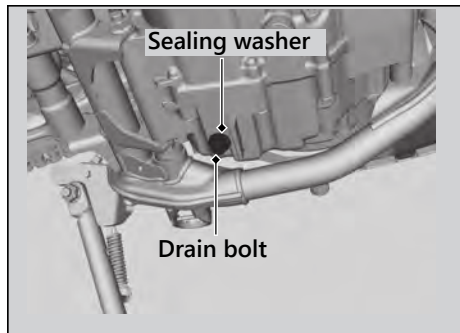

7. Remove the oil filter cover, oil filter, spring and gasket by removing the oil filter cover bolts.
  - Discard the oil and oil filter at an approved recycling center.