

## Recommended Fork Oil

Suggested oil	HP Fork Oil, SS-19
---------------	--------------------

## Right Fork Oil Change

Refer to *Fork Removal* on page 89 for front suspension removal.

1. Remove the fork protector socket bolts (1) and fork protector (2).

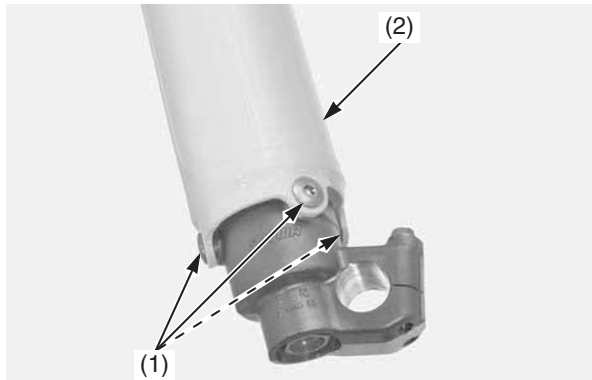

(1) fork protector socket bolts  
(2) fork protector

2. Clean the fork assembly, especially the sliding surface of the slider and dust seal.

3. Hold the outer tube (3), then remove the fork damper (4) from the outer tube using a lock nut wrench (5). Gently slide the outer tube down onto the lower end (axle holder) (6).
- Lock nut wrench 07WMA-KZ30100

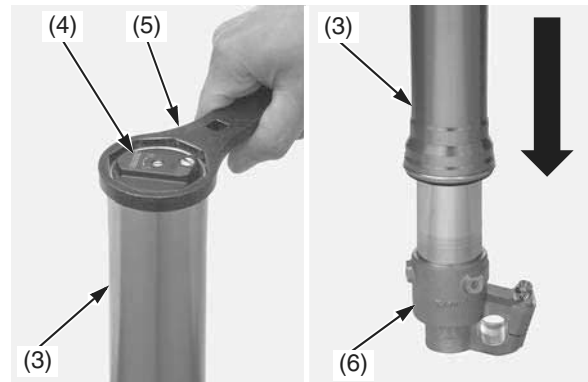

(3) outer tube  
(4) fork damper  
(5) lock nut wrench  
(6) axle holder

### NOTICE

The outer tube (3) can drop on the slider (8) and damage the fork dust seal (7). To avoid damage, hold both the outer tube and slider when removing the fork damper.

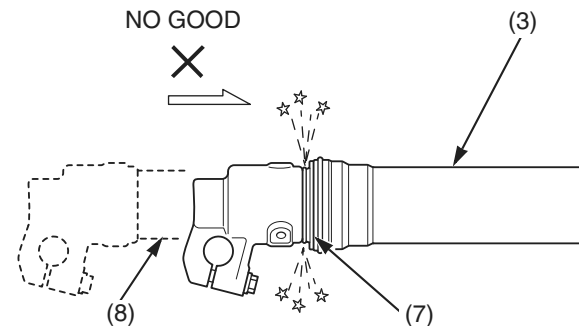

(3) outer tube  
(8) slider  
(7) fork dust seal

4. Drain the fork oil from the outer tube (3). Drain the fork oil from the oil holes (9) of the fork damper.

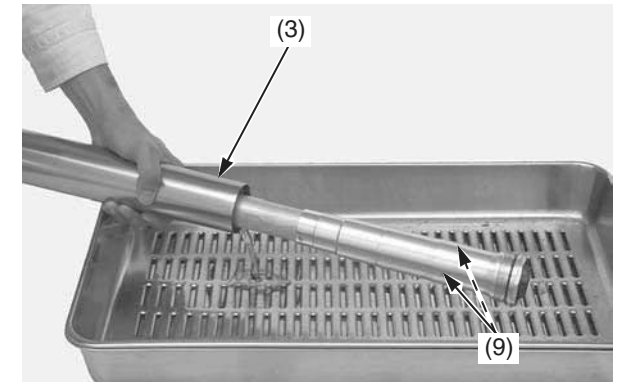

(3) outer tube  
(9) oil holes

5. Drain the fork oil by turning the outer tube (3) upside down. (About 0.2 US oz (7 cm<sup>3</sup>) of fork oil will be left in the outer tube when it is left inverted for about 20 minutes at 68°F/20°C.)

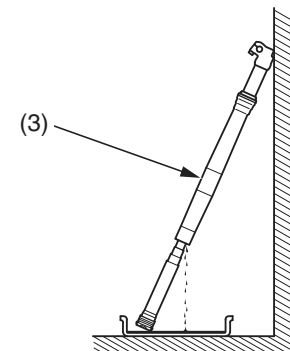

(3) outer tube

Pour the drained oil into a suitable container and dispose of it in an approved manner (page 158).

### NOTICE

*Improper disposal of drained oil is harmful to the environment.*

(cont'd)