

Front Suspension Adjustments

9. Measure the clearance between the fork center bolt lock nut (2) and fork center bolt (12).
Standard: 0.06 – 0.08 in (1.5 – 2.0 mm)

If the clearance is out of specification, check the fork center bolt lock nut and fork center bolt installation.

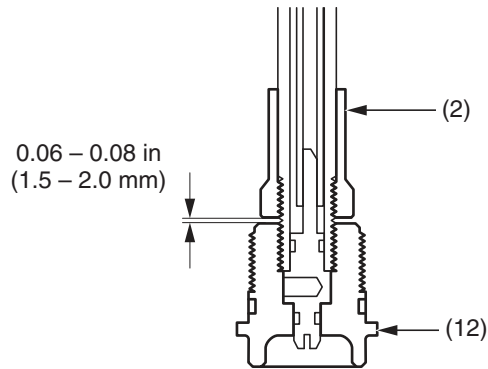

(2) fork center bolt lock nut (12) fork center bolt

10. Tighten the fork center bolt lock nut (2) to the fork center bolt (12) closely by hand. Tighten the fork center bolt lock nut to the specified torque:
16 lbf-ft (22 N·m, 2.2 kgf·m)

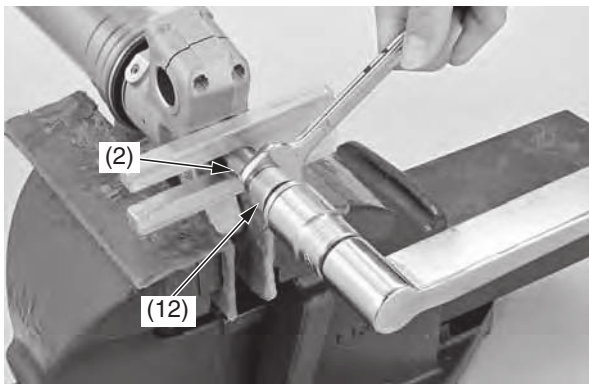

(2) fork center bolt lock nut
(12) fork center bolt

11. Remove the piston base or mechanic's stopper tool while pushing the fork damper. Apply locking agent to the fork center bolt threads. Install the fork center bolt (12) to the axle holder and tighten it to the specified torque:
51 lbf-ft (69 N·m, 7.0 kgf·m)

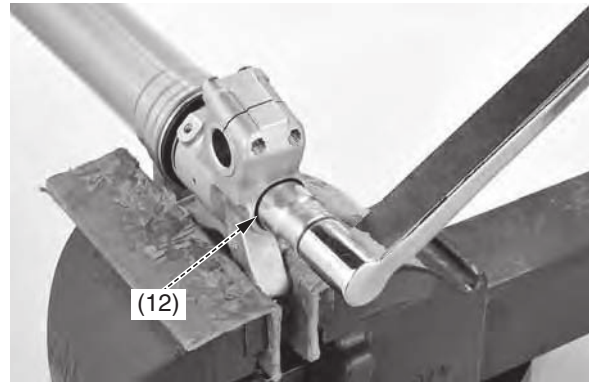

(12) fork center bolt

12. Measure the length between the axle holder and outer tube.
Standard: 12.5 ± 0.1 in (316.5 ± 2 mm)
13. Compare the length (13) at assembly and at disassembly. They should be the same length.

If the length at assembly is longer than at disassembly, check the fork center bolt and fork center bolt lock nut installation.

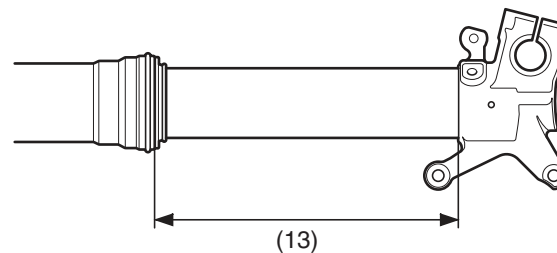

(13) length

14. Remove the fork damper from the fork.
15. Pour the recommended fork oil (14) into the fork assembly (1)

Recommended Oil: HP Fork Oil, SS-19

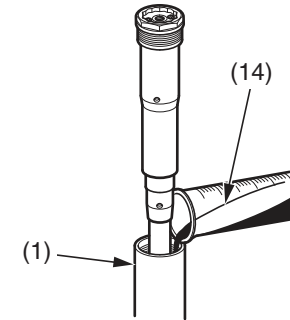

(1) fork assembly

(14) fork oil