

General Competition Maintenance

Steering Head Bearings

Periodically clean, inspect and regrease the steering head bearings — especially if wet, muddy or extremely dusty courses are encountered often.

Use urea based multi-purpose grease designed for high temperature, high pressure performance (example: EXCELITE EP2 manufactured by KYODO YUSHI, Japan or Shell Stamina EP2 or equivalent).

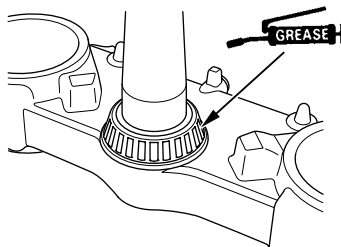

Fork Oil/Performance

Disassemble, clean and inspect the front fork and replace oil regularly. Contamination due to the tiny metal particles produced from the normal action of the fork, as well as normal oil breakdown, will deteriorate the performance of the suspension. Refer to the Honda Service Manual. Use only HP Fork Oil, SS-19 or equivalent which contains special additives to assure maximum performance of your CRF's front suspension.

Frame

Because your CRF is a high-performance machine, the frame should not be overlooked as part of your overall competition maintenance program. Periodically inspect the frame closely for possible cracking or other damage. It makes good racing sense.

Spokes

Check spoke tension frequently between the first few rides. As the spokes, spoke nuts and rim contact points seat-in, the spokes may need to be retightened. Once past this initial seating-in period, the spokes should hold their tension. Still, be sure your race maintenance program includes checking spoke tension and overall wheel condition on a regular basis (page 90).

Nuts, Bolts, Etc

Application of a thread locking agent to essential fasteners offers added assurance and security. Remove the nuts, clean the threads of both the nuts and bolts, apply Pro Honda Hondalock or an equivalent and tighten to the specified torque.

Gaskets

Always use new gaskets when reassembling components.

Cylinder Removal

Put a little grease on the cylinder mounting dowels to prevent corrosion from dissimilar metals. The tolerances are extremely tight, so it's important to keep these dowels absolutely clean (pages 72, 75).

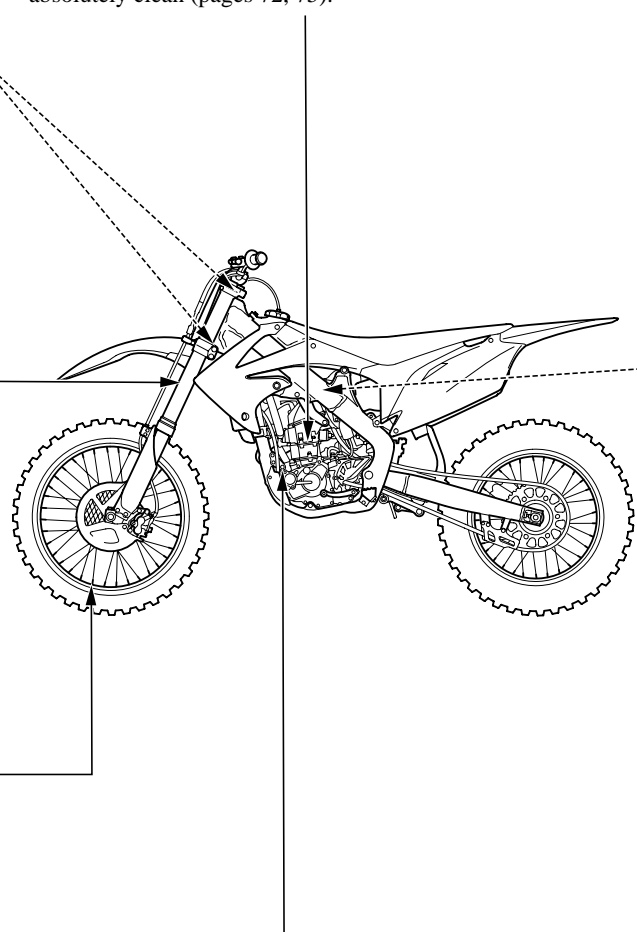

Fuel Line

Refer to *Fuel System* on page 40. Check the fuel line for deterioration, damage, or leakage. Replace the fuel line every year.

Electrical Connectors

Clean electrical connectors and wrap them with electrical tape to reduce the possibility of unwanted disconnections, water shorts or corrosion. For additional corrosion protection, apply Pro Honda Dielectric Grease to all the electrical connections.

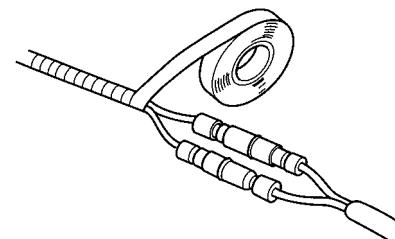

Engine Mounting Bolts and Nuts

Make sure the engine mounting bolts and nuts are tightened to the proper torque specification. For added peace of mind, remove the nuts, clean the threads, and apply Pro Honda Hondalock or an equivalent before torquing the nuts.