

## Rear Suspension Damping

### Compression Damping

Compression damping can be adjusted with the adjuster located on the rear shock absorber's reservoir.

The compression damping adjuster has 3 turns or less.

To increase damping, turn the adjuster screw clockwise.

To decrease damping, turn the screw counterclockwise.

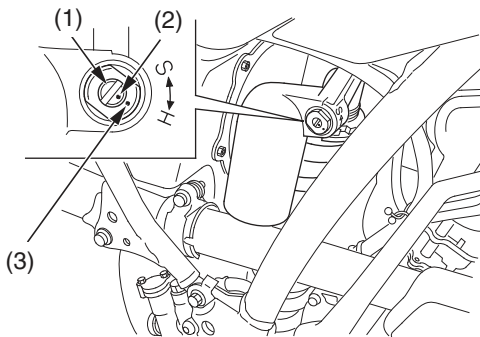

(1) compression damping adjuster (3) reference mark  
(2) punch mark

To adjust to the standard position:

1. Turn the compression damping adjuster (1) clockwise until it will no longer turn (lightly seats). This is the full hard position.
2. Turn the adjuster counterclockwise 1 – 1 1/4 turns, and make sure that the punch mark (2) on the adjuster aligns with the reference mark (3) on the shock absorber.

### Rebound Damping

The rebound damping adjuster (1) is located at the lower end of the shock absorber.

The rebound damping adjuster has 3 turns or less.

To increase damping, turn the adjuster screw clockwise.

To decrease damping, turn the adjuster screw counterclockwise.

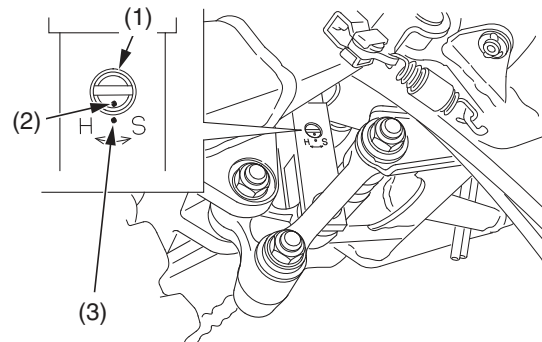

(1) rebound damping adjuster (3) reference mark  
(2) punch mark

To adjust to the standard position:

1. Turn the adjuster clockwise until it will no longer turn (lightly seats). This is the full hard position.
2. Turn the adjuster counterclockwise 3/8 – 5/8 turns, and make sure that the punch mark (2) on the adjuster aligns with the reference mark (3) on the shock absorber.