

Valve Clearance

Camshaft Holder Assembly Installation

1. While holding the cam chain, rotate the primary drive gear bolt (1) (crankshaft) clockwise and align the punch mark (2) with the index mark (3).

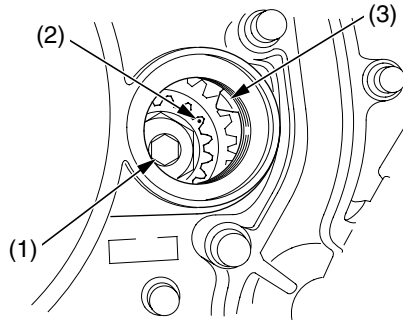

- (1) primary drive gear bolt
- (2) punch mark
- (3) index mark

2. Install the newly selected shims (4) on the valve spring retainers (5).

NOTICE

Do not let the shims fall into the crankcase.

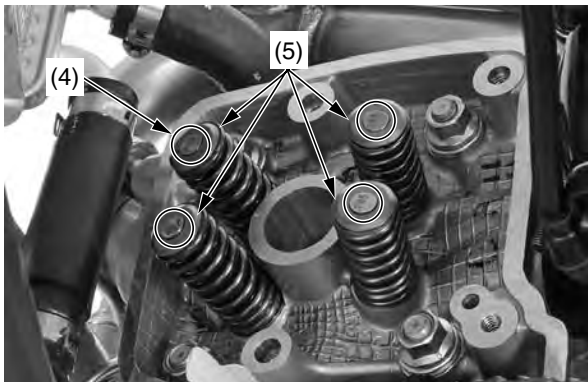

- (4) shims
- (5) v alve spring retainers

3. Apply molybdenum disulfide oil (a mixture of 1/2 engine oil and 1/2 molybdenum disulfide grease containing more than 3% molybdenum disulfide additive) to the outer surface of each valve lifter (6).
4. Install the valve lifters in their original location into the camshaft holder assembly.
5. Apply oil to new O-ring (7) and install it.

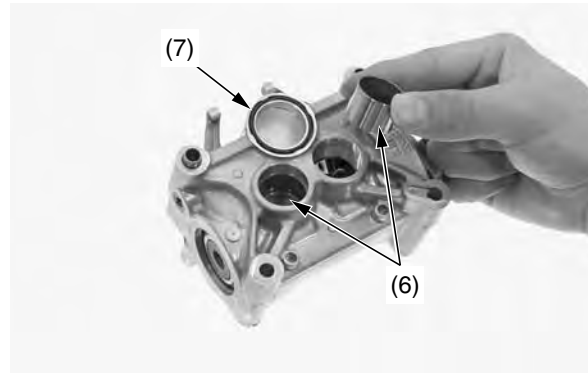

- (6) valve lifters
- (7) O-ring

6. Apply molybdenum disulfide oil (a mixture of 1/2 engine oil and 1/2 molybdenum disulfide grease containing more than 3% molybdenum disulfide additive) to the surface of the cam lobes.

Install the camshaft holder assembly onto the cylinder head aligning the index line (8) on the camshaft flange with the index mark (9) on the camshaft holder as illustrated above. Apply oil to the camshaft holder assembly bolt threads and seating surface.

Align the camshaft holder assembly bolt holes (10) with the rocker arm shaft cut-outs (11). Tighten the camshaft holder assembly bolts (12) in a crisscross pattern in two or three steps to the specified torque:
10 lbf-ft (13 N·m, 1.3 kgf·m)

NOTICE

Do not let the bolts and valve lifters fall into the crankcase.

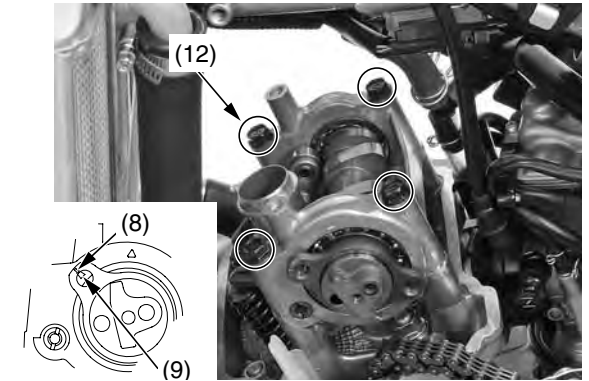

- (8) index line
- (9) index mark
- (12) camshaft holder assembly bolts

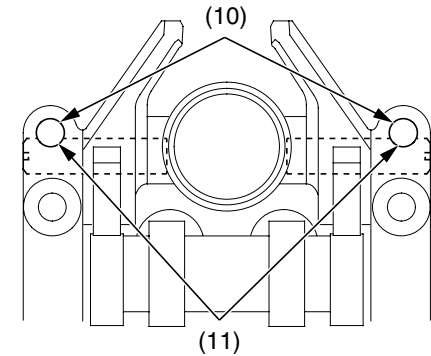

- (10) camshaft holder assembly bolts holes
- (11) rocker arm shaft cut-outs