

CMX300A only

When removing and installing the wheel, be careful not to damage the wheel speed sensor and pulser ring.

Front Wheel

Removal

1. Place your motorcycle on a firm, level surface.
2. Remove the front axle bolt.

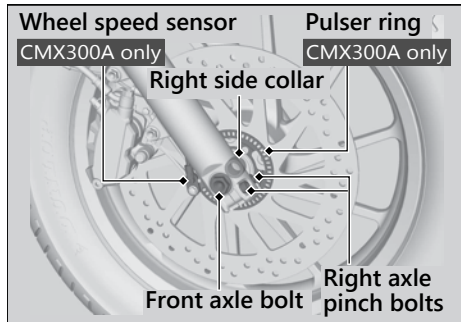

3. Loosen the right and left axle pinch bolts.
4. Support your motorcycle securely and raise the front wheel off the ground using a maintenance stand or a hoist.
5. Remove the front axle shaft, front wheel and side collars.
 - Avoid getting grease, oil, or dirt on the disc or pad surfaces.
 - Do not pull the brake lever while the wheel is off the motorcycle.

