

Adjusting the Rear Suspension

Spring Preload

You can adjust the spring preload by the adjuster to suit the load or the road surface. Use the cloth and pin spanner to turn the adjuster. Position 1 to 2 is for a decrease spring preload (soft), or turn the position 4 to 10 increase spring preload (hard). The standard position is 3.

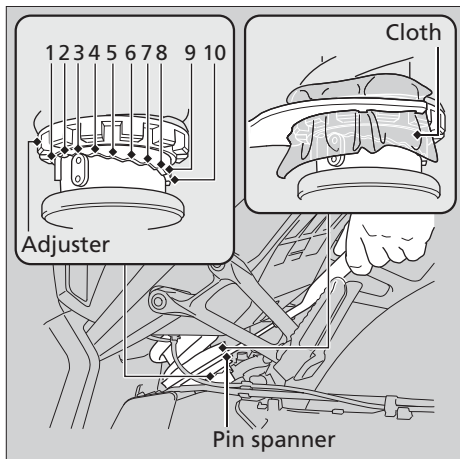

Attempting to adjust directly from 1 to 10 or 10 to 1 may damage the shock absorber.