

INSPECTION

Check the caliper cylinders and pistons for scratches, scoring or other damage.

Measure the cylinder inside diameter and piston outside diameter.

SERVICE LIMITS:

CYLINDER I.D.: 25.46 mm (1.002 in)

PISTON O.D.: 25.30 mm (0.996 in)

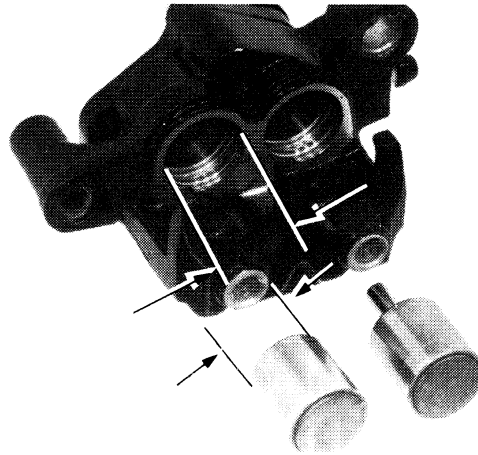

ASSEMBLY

Coat new dust and piston seals with clean brake fluid and install them in the seal groove in the caliper.

Lubricate the caliper cylinders and pistons with brake fluid, and install the pistons with the piston pad end facing the pad.

Apply silicone grease to the pivot collar and boots. Install the collar and boots making sure that the boots are seated in the collar and caliper grooves properly.

Install the pad spring and shim.

Install the pads and pad pin bolts.

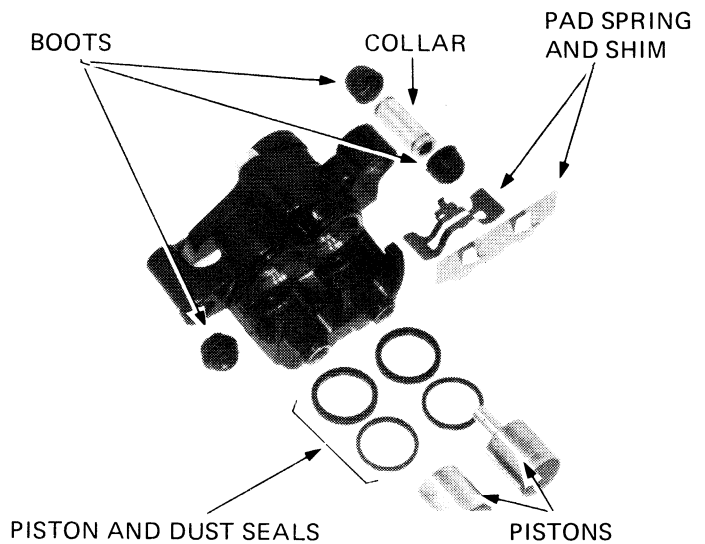

PARKING BRAKE MECHANISM

Remove the parking brake attaching bolts and parking brake from the caliper.

