

Install the metering unit into the reservoir.
 Install the valve into the reservoir being careful not to damage the O-ring and tighten it with the special tool.
 Install the two springs, detent balls and adjusting knob onto the valve. Align the flats on the adjusting knob and the adjusting screw.
 Tighten the knob screw securely.

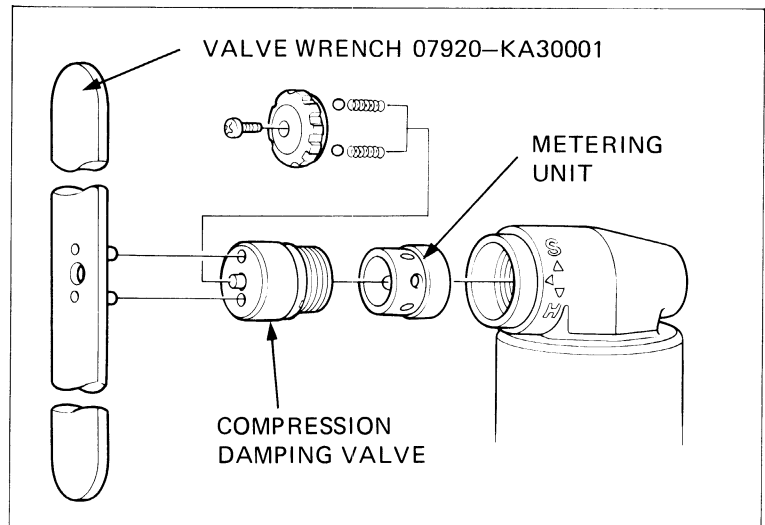

Hold the upper shock mount in a vise with soft jaws or a shop towel. Point the hole straight up.
 Pull out the damper rod all the way.
 Fill the damper with ATF.

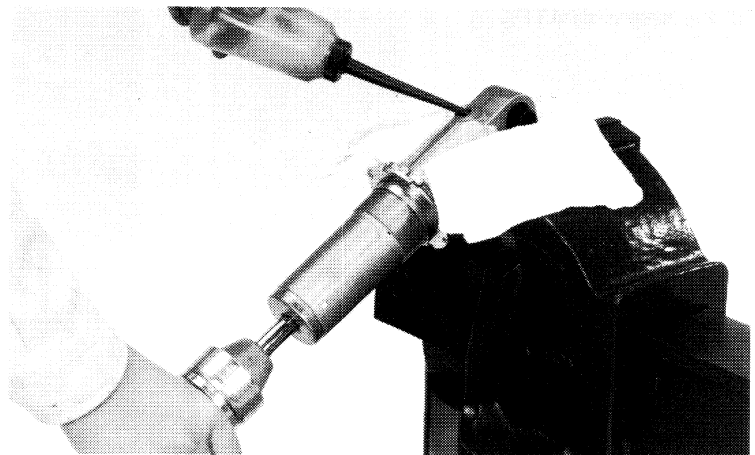

Bleed air from the damper by moving the damper rod with short strokes, in and out several times slowly.
 Fill the damper with ATF as required.

NOTE

The damper should be as free of air as possible.

