

BEARING HOLDER INSTALLATION

Install new O-rings in the groove of the bearing holder.
Apply grease to the outside surfaces of the bearing holder.

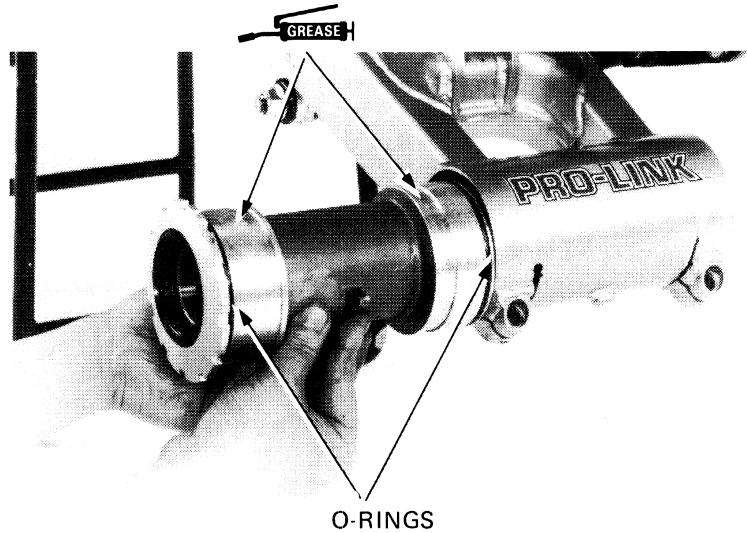

'85:
Install the bearing holder into the swing arm as shown in the figure.

AFTER '85:
Install the bearing holder into the swing arm after aligning the center tang on the bearing holder with the punch mark on the swing arm.

'85 AND AFTER '85:
Install the rubber seals, and stopper bolt.
Apply grease to the caliper mount plate installation surface of the bearing holder.
Tighten the socket bolt to the specified torque.

TORQUE: 18–25 N·m
(1.8–2.5 kg·m, 13–18 ft·lb)

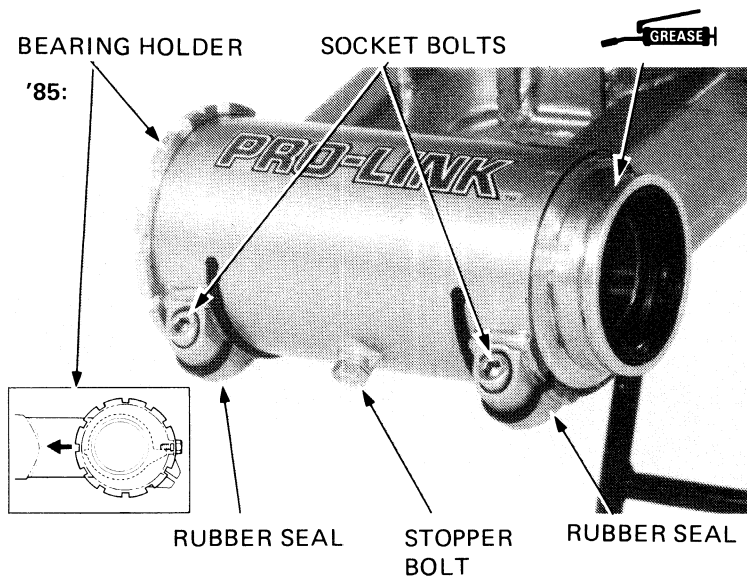

AFTER '85:

