

TRANSMISSION/CRANKSHAFT/BALANCER

Install the primary drive gear.
Install the washer with its "OUT" mark out.
Hold the rotor with a universal holder and tighten the bolt.

TORQUE: 40–50 N·m
(4.0–5.0 kg·m, 29–36 ft·lb)

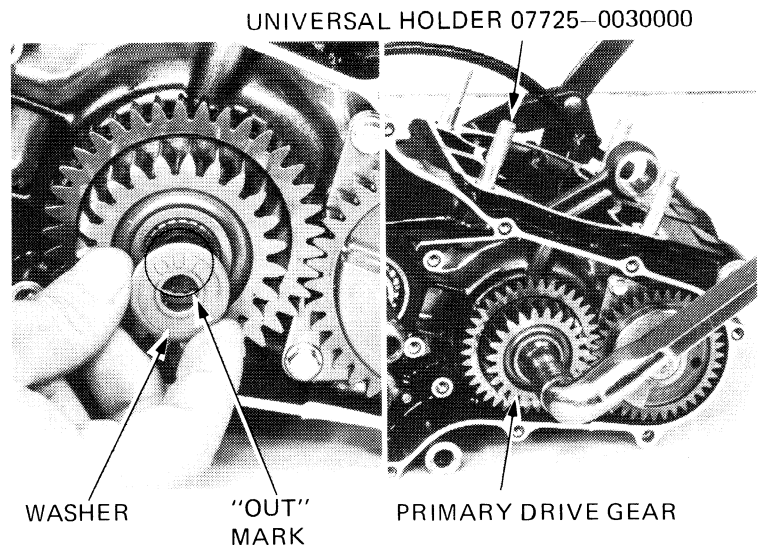

CRANKCASE SEPARATION

Remove the balancer (Page 8-3).
Remove the crankcase attaching bolts and balancer bearing holder.

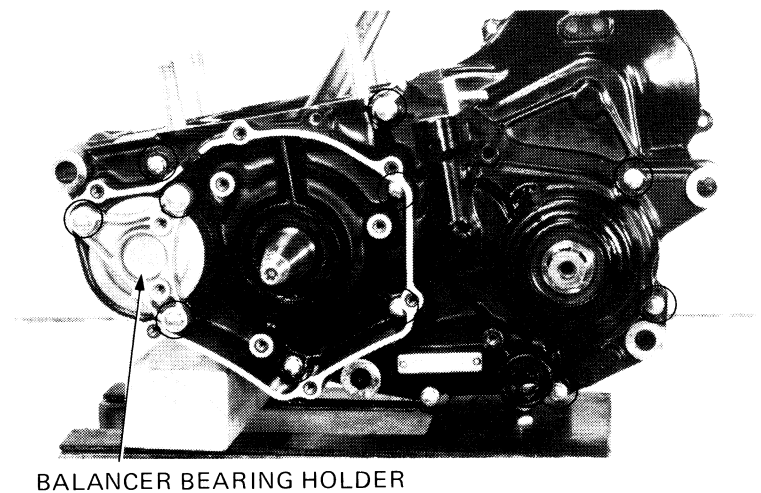

Remove the right crankcase from the left crankcase while tapping them at several locations with a soft hammer.
Attach the crankcase puller to the right crankcase and separate the crankcase halves.

CAUTION

Do not pry the crankcase halves apart with the end of a screwdriver.

Remove the gasket and dowel pins.

