

- (1) FRONT FENDER
- (2) NUMBER PLATE
- (3) TOP BRIDGE
- (4) BOTTOM BRIDGE
- (5) FORK LEG

## Fork

### Removal

Remove the front wheel (page 5-1).

Remove the front fender and number plate.  
Loosen the top bridge pinch bolt.

If the forks are to be disassembled, loosen the fork bolt.

### NOTICE

*To avoid damaging the fork bolt threads, loosen the top bridge pinch bolt before loosening the fork bolts.*

Loosen the bottom bridge pinch bolts, and pull the fork tube down and out.

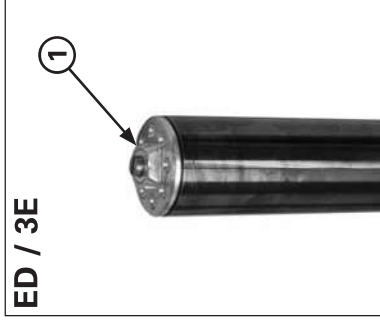

ED / 3E

(1)

(1) FORK BOLT

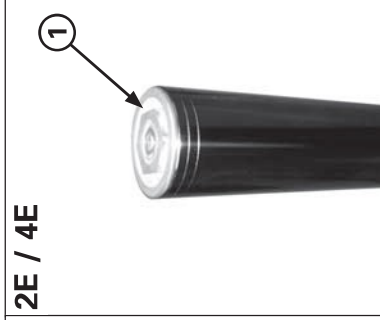

2E / 4E

(1)

(1) DAMPER ADJUSTER CASE  
(2) FORK BOLT

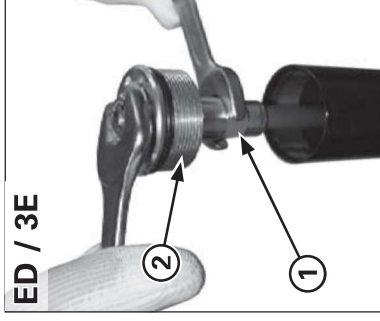

ED / 3E

(2)

(1)



Make sure the damping adjuster is in clicked position and is not in between the position.  
Hold the damper adjuster case and remove the fork bolt from the damper adjuster case.  
Do not remove the damper adjuster case from the damper rod.

Pour out the fork fluid.