

Rear Suspension Damping

Refer to *Safety Precautions* on page 71.

Rebound Damping

LEFT REAR

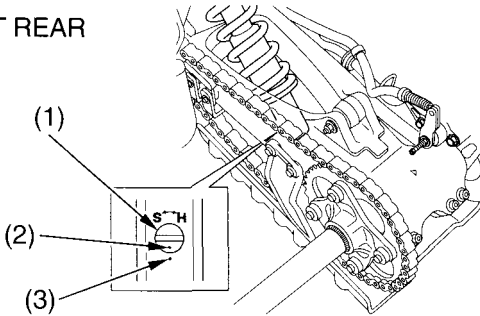

- (1) rebound damping adjuster (3) reference punch mark
(2) punch mark

To adjust to the standard position:

1. Turn the rebound damping adjuster (1) clockwise until it will no longer turn (lightly seats). This is the full hard setting.
2. Turn the adjuster counterclockwise approximately $1 \frac{7}{8}$ turns so that the punch mark (2) on the adjuster aligns with the reference punch mark (3). This is the standard position.

To Reduce Rebound Damping (SOFT):

For a light load and smooth road conditions, turn the adjuster counterclockwise toward SOFT (S).

To Increase Rebound Damping (HARD):

For a firmer ride and rough road conditions, turn the adjuster clockwise toward HARD (H).