

High Air Temperature

35 °C (95 °F) or above

1. Do not use the choke.
2. With the throttle slightly open, push the starter button.

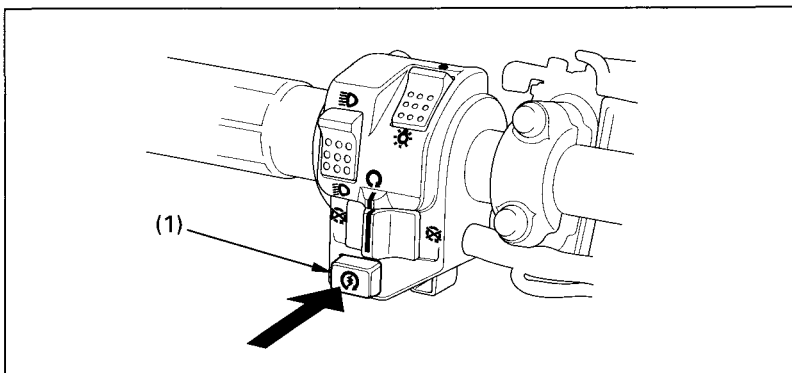

Fig. 3-10

(1) Starter button

Low Air Temperature

10 °C (50 °F) or below

1. Follow step 1 – 2 under “Normal Air Temperature”.

NOTE:

If the engine does not start after several attempts, operate the starter button after opening and closing the throttle lever several times.

2. Warm up the engine by opening and closing the throttle slightly.
3. When the engine begins to run slightly rough, push the choke lever (Fig. 3-9) down to the halfway position (B).
4. Continue warming up the engine until it runs smoothly and responds to the throttle, then push the choke lever (Fig. 3-9) down all the way to fully OFF (A).
5. If idling is unstable, open the throttle slightly.

CAUTION:

- * **Extended use of the choke may impair piston and cylinder wall lubrication and shorten the life of the engine.**
- * **Do not race the engine during the warm-up period.**
Racing a cold engine wastes fuel and increases engine wear.