

Inspection

The reserve tank (1) is behind the right body cover.

Check the coolant level in the reserve tank while the engine is at the normal operating temperature with the scooter in an upright position. If the coolant level is below the LOWER level mark (2), add coolant mixture until it reaches the UPPER level mark (3).

Always add coolant to the reserve tank. Do not attempt to add coolant by removing the radiator cap.

If the reserve tank is empty, or if coolant loss is excessive, check for leaks and see your Honda dealer for repair.

To remove the reserve tank cap:

1. Remove the right floor mat (4).
2. Remove the reserve tank lid (5) using a flat head driver (6) with a protective cloth.
3. Remove the reserve tank cap (7).

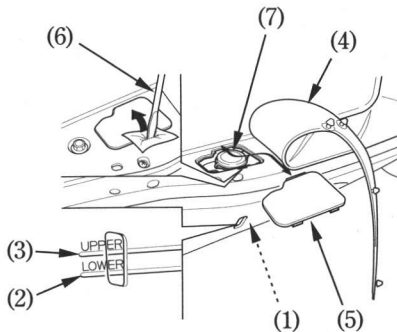

- | | |
|----------------------|----------------------|
| (1) Reserve tank | (5) Reserve tank lid |
| (2) LOWER level mark | (6) Flat head driver |
| (3) UPPER level mark | (7) Reserve tank cap |
| (4) Floor mat | |