

Check that the fluid level is above the LOWER level mark (1) with the motorcycle in an upright position.

Brake fluid must be added to the reservoir whenever the fluid level begins to reach the LOWER level mark (1). Remove the screws (2), reservoir cover (3), diaphragm plate (4), diaphragm (5), and float (6). Fill the reservoir with DOT 3 or 4 BRAKE FLUID from a sealed container up to the upper level mark (7). Reinstall the float, diaphragm, diaphragm plate, and cover. Tighten the screws securely.

Other Checks :

Make sure there are no fluid leaks. Check for deterioration or cracks in the hoses and fittings.

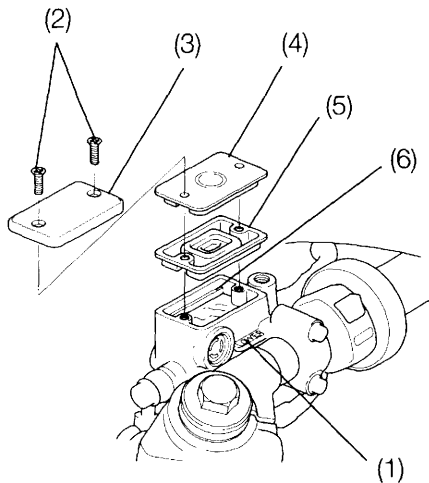

- | | |
|----------------------|---------------------|
| (1) LOWER level mark | (4) Diaphragm plate |
| (2) Screws | (5) Diaphragm |
| (3) Reservoir cover | (6) Float |