

## IDLE SPEED

Refer to the Safety Precautions on page 60 .

The engine must be at normal operating temperature for accurate idle speed adjustment. Ten minutes of stop-and-go riding is sufficient.

Do not attempt to compensate for faults in other systems by adjusting idle speed. See your authorized Honda dealer for regularly scheduled carburetor adjustments, including individual carburetor adjustment and synchronization.

1. Warm up the engine, shift to neutral and place the motorcycle on its stand.
2. Adjust idle speed with the throttle stop screw (1).

Idle speed (in neutral):

$900 \pm 100$  rpm

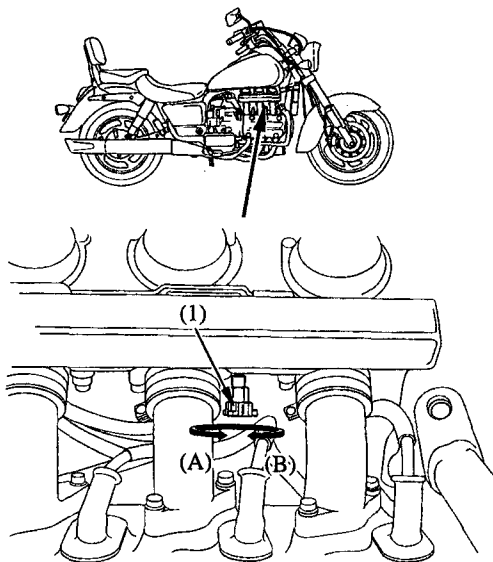

(1) Throttle stop screw

(A) Increase

(B) Decrease