

Suspension

Recommended Fork Oil

viscosity (weight)	5 W
suggested oil	Pro Honda HP Fork Oil or equivalent

Fork Oil Change

Refer to *Front Suspension Disassembly* on page 113.

1. Clean the fork assembly, especially the sliding surface of the slider and dust seal.
2. Record the rebound damping adjuster position and turn the adjuster counterclockwise until it stops.
3. Hold the outer tube (1), then remove the fork damper (2) from the outer tube using the lock nut wrench (3). Gently slide the outer tube down onto the lower end of the slider (4).

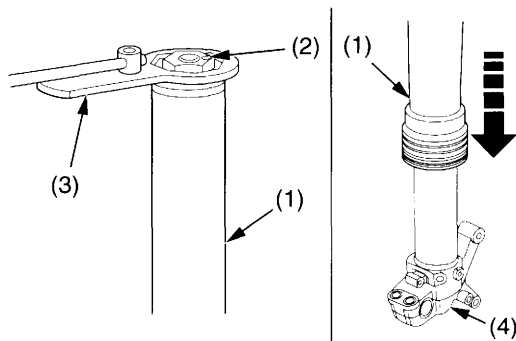

(1) outer tube
(2) fork damper

(3) lock nut wrench
(4) slider, lower end

NOTICE

The outer tube (1) can drop on the slider (5) and damage the fork dust seal (6) and guide bushing (7) when the fork damper is removed. To avoid damage hold both the outer tube and slider when removing the fork damper.

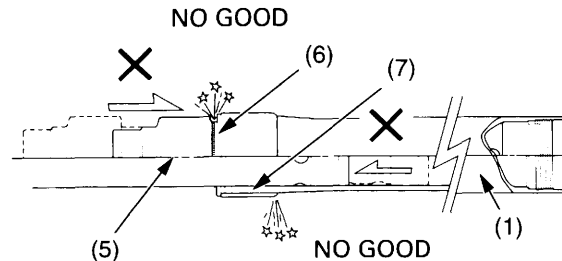

(1) outer tube
(5) slider

(6) fork dust seal
(7) guide bushing

4. Drain the fork oil from the outer tube (1). Drain the fork oil from the oil holes (8) of the fork damper.

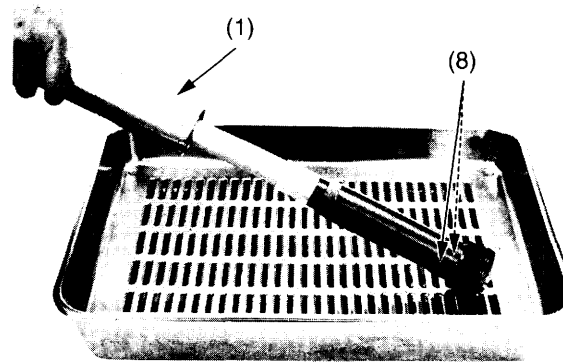

(1) outer tube

(8) oil holes

5. Drain the fork oil by turning the outer tube (1) upside down. (About 0.4 US oz (12 cm³) of fork oil will be left in the outer tube when it is left inverted for about 20 minutes at 20 °C/68°F.)

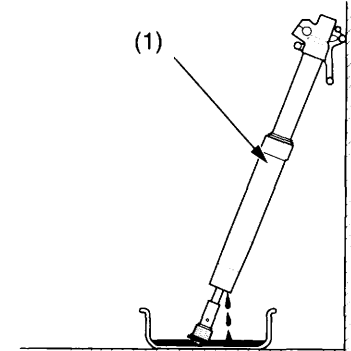

(1) outer tube

Pour the drained oil into a suitable container and dispose of it in an approved manner (page 151).

NOTICE

Improper disposal of drained oil is harmful to the environment.

Amount of fork oil left in the fork (within damper and spring)

unit: cm³

minute	5	10	20	35	55	85	145
30/86	27	15.3	10.6	9.4	8.3	7.9	7.9
20/68	29.4	16.5	11.8	10.6	9.4	8.2	8.2
10/50	28.2	21.2	16.5	15.3	12.9	11.8	11.8
0/32	30.6	22.4	18.8	16.5	16.5	15.3	14.1

