

Rear Suspension Adjustments

Rear Suspension Race Sag

Setting the proper race sag (ride height) is very important for competition use.

Race sag refers to the amount of rear wheel travel used by your CRF at rest, ready to ride, with you on the seat. As a general rule of thumb, the race sag dimension should be about one-third of the maximum travel.

On your CRF, ride height is changed by adjusting the rear suspension spring pre-load.

Spring Pre-load & Race Sag Adjustment

The following adjustment procedure establishes the correct starting point for any suspension tuning — the proper rear suspension spring preload adjustment for your specific needs.

Your CRF should be at normal racing weight, including fuel, oil and coolant. You should be wearing all your normal protective apparel. You will need two helpers.

To calculate the proper adjustment, it is necessary to measure between two fixed points — from the centre of the rear fender mounting bolt to the centre of the chain adjuster lock nut as illustrated here — for three different situations:

unloaded: motorcycle on an optional workstand with rear suspension fully extended, no rider.

loaded with rider: motorcycle on ground, with rider.

loaded without rider: motorcycle on ground, without rider

1. Support your CRF on an optional workstand with the rear wheel off the ground.
2. Measure the *unloaded* dimension.

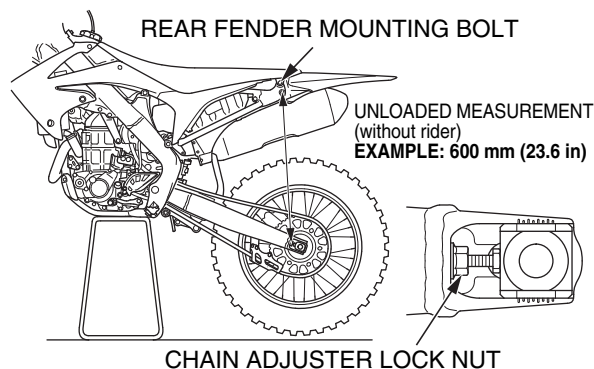

3. Measure the *loaded with rider* dimension. Remove the workstand. With two helpers available, sit as far forward as possible on your CRF's seat, wearing your riding apparel. Ask one helper to steady your CRF perfectly upright so you can put both feet on the pegs. Bounce your weight on the seat a couple of times to help the suspension overcome any situation and settle to a good reference point.

Ask the other helper to measure the *loaded with rider* dimension.

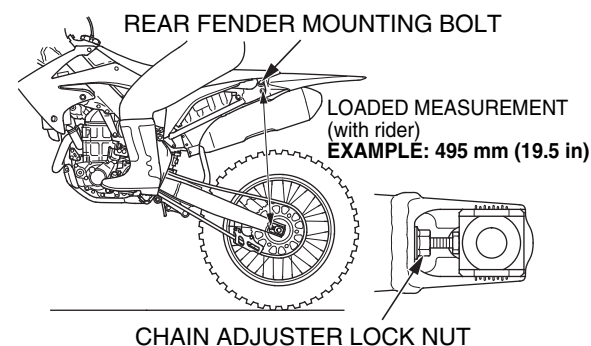

Example:

Unloaded = 600 mm (23.6 in)

– Loaded = 495 mm (19.5 in)

Race Sag = 105 mm (4.1 in)

4. Calculate the *race sag* dimension.

To do this, subtract the *loaded with rider* dimension (step 3) from the *unloaded* dimension (step 2).

Standard Race Sag: 105 mm (4.1 in)

Adjust spring pre-load as necessary to obtain the desired handling results.

Decreasing the race sag dimension (example: 95 mm, 3.7 in) improves turning ability for tight terrain at the cost of slightly reduced straight line stability.

Increasing the race sag dimension (example: 115 mm, 4.5 in) may improve stability on faster terrain with less turns, but will reduce turning performance slightly and may upset the balance between the front and rear suspension, producing a harsher ride. This will happen if the adjustment shifts the effective wheel travel toward the more progressive end of its range.