

Valve Clearance

8. Make sure that the timing mark (12) on the cam sprocket aligns with the camshaft holder mating surface (13) of the cylinder head.

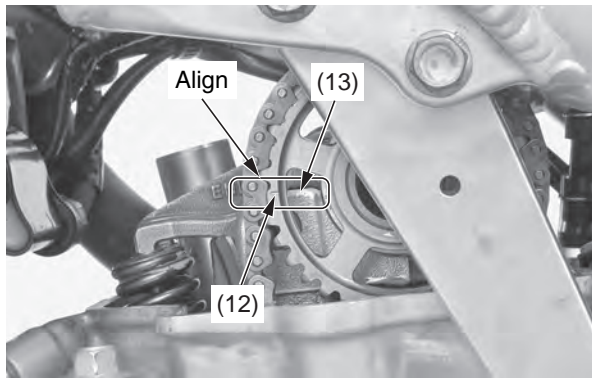

(12) timing mark
(13) camshaft holder mating surface

9. Make sure that the dowel pins (14) are installed into the camshaft holder (15).

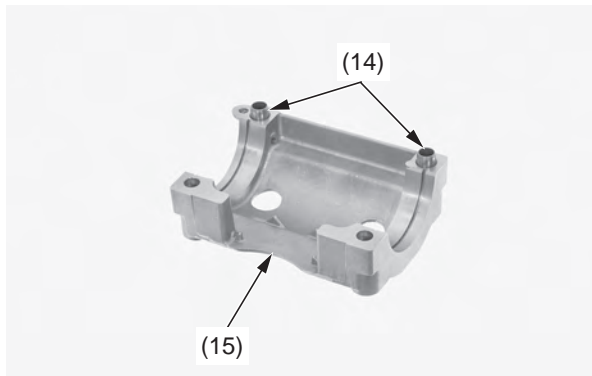

(14) dowel pins (15) camshaft holder

10. Install the set rings (16) on the camshaft bearing grooves (17).

NOTICE

Do not let the set rings fall into the crankcase.

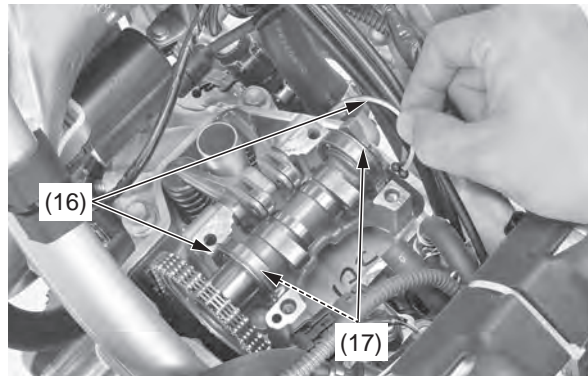

(16) set rings
(17) camshaft bearing grooves

11. Apply engine oil to the camshaft holder bolt threads and seating surface. Install the camshaft holder (18) with the “ Δ ” mark (19) facing forward. Tighten the camshaft holder bolts (20) (21) to the specified torque:

14 N·m (1.4 kgf·m, 10 lbf·ft)

Tighten the camshaft holder bolts in a criss-cross pattern in two or three steps.

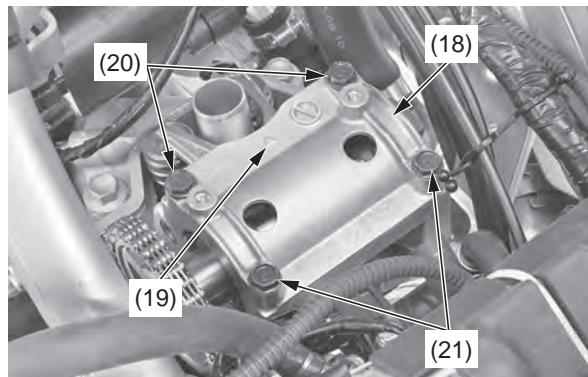

(18) camshaft holder (20) camshaft holder bolts (long)
(19) “ Δ ” mark (21) camshaft holder bolts (short)

12. Remove the tensioner stopper (22) from the cam chain tensioner lifter.

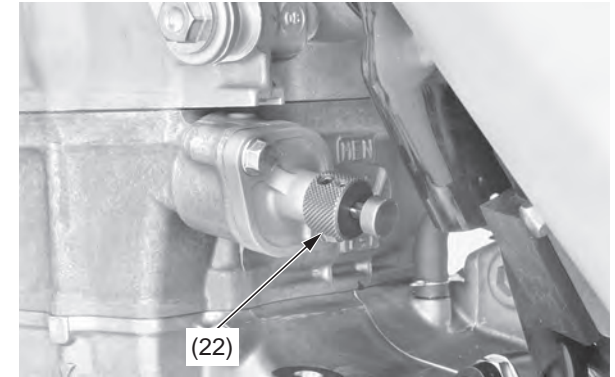

(22) tensioner stopper

13. Make sure that the piston is at TDC on the compression stroke (page 72). Check that the timing mark (12) on the cam sprocket aligns with the camshaft holder mating surface (13) of the cylinder head. If the timing mark doesn't align with the camshaft holder mating surface, remove the cam chain and realign the timing mark.

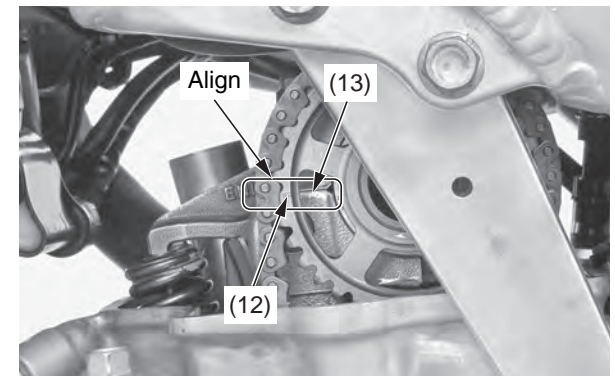

(12) timing mark
(13) camshaft holder mating surface